

LOCOMOTIVE FEEDWATER HEATING EQUIPMENTS

Serial 2517

Edition 1

ARRANGEMENT AND OPERATION

INTRODUCTION

1. **Comparison Between Injector and Pump.**—As far as fuel costs are concerned there is practically no difference whether a boiler is supplied with feedwater by an injector or by a pump. An injector requires much ^{http://www.libgen.us} more steam to deliver the same quantity of water to the boiler than a pump, because the injector heats the feedwater, whereas the pump does not. It would seem, then, that a pump would be the more economical device to use. However, a proper comparison between the merits of the two devices does not stop at the delivery of the feedwater to the boiler. After the cold water delivered to the boiler by the pump absorbs enough heat to raise the water to the same temperature as that delivered by the injector, the cost in fuel of feeding the boiler is about the same in both cases. The cost of the operation of a pump is slightly greater because the exhaust steam from a pump is wasted, whereas an injector is practically a pump in which the actuating steam is condensed.

2. **Heating Feedwater.**—When considering the feeding of the boiler by feedwater heating equipment, it must not be overlooked that the injector is also a feedwater heating device. However, with the injector, the heating of the feedwater is done by live steam from the boiler; with feedwater heating equipment, the water is heated by exhaust steam that otherwise would be wasted. The saving in the employment of feedwater heating

equipment is, then, brought about by using exhaust steam instead of steam from the boiler to heat the feedwater.

The use to which the saving is put will vary on different railroads as well as under different operating conditions. If it is desired to effect an actual reduction in fuel consumption, then the same train loads and the same speeds could be maintained with less fuel than before the feedwater equipment was applied. If, on the other hand, an increase in the earning capacity per locomotive mile is desired, which is usually the case, then the fuel consumption would remain the same as before the feedwater equipment was installed, and the saving due to the sustained and increased boiler capacity would be reflected in a higher drawbar pull and hence the movement of heavier tonnage at higher speeds.

3. The saving in fuel with feedwater heating equipment and with the same weight and speed of train is due to the fact that heat is being returned to the boiler other than by way of the firebox, this requiring the burning of less fuel. The increase in the steam-generating capacity of the boiler is due to not taking steam from the boiler to heat the feedwater as with an injector, the saving in fuel being then equivalent to an increase in the capacity of the boiler to generate steam by an equal amount. Against the saving in fuel or the increase in the capacity of the boiler must, of course, be charged the greater cost of the feedwater apparatus, as well as the cost of its maintenance as compared with an injector.

4. The reason why a pump is selected to deliver the water to the boiler when the heating of feedwater is considered, is that if an injector were used it would be merely a matter of adding a small quantity of heat to feedwater that was already heated by live steam. This would result in only a small saving in comparison with that made by a feedwater pump where all the heating of the feedwater is done by exhaust steam. With an injector operating at capacity, the water is heated by steam from the boiler to a temperature of about 160° F. If then put through a heater the temperature could possibly be raised about 75 degrees higher. With a feedwater heating apparatus, all of the heating

is done by the exhaust steam, that is, the feedwater may be raised from 60° F. to 235° F., or a total of 175 degrees, with heat that would otherwise escape unused.

5. **Heat Used When Forcing Water With Injector.**—It is not possible to force water with an injector without raising its temperature a considerable amount. Hence, an injector is an extremely wasteful device if the temperature of the water that is to be delivered is immaterial, that is, if it is not necessary that the water be heated. This waste is due to the large volume of steam that is absorbed by the water before it is raised to a velocity that will permit it to be forced into the boiler. Actually, only a small amount of steam or heat is required to force the water into the boiler in comparison with the amount absorbed in heating the water. A pump is much more economical when the delivered water does not require to be heated, but an injector would be equally as economical if it could force water without heating it.

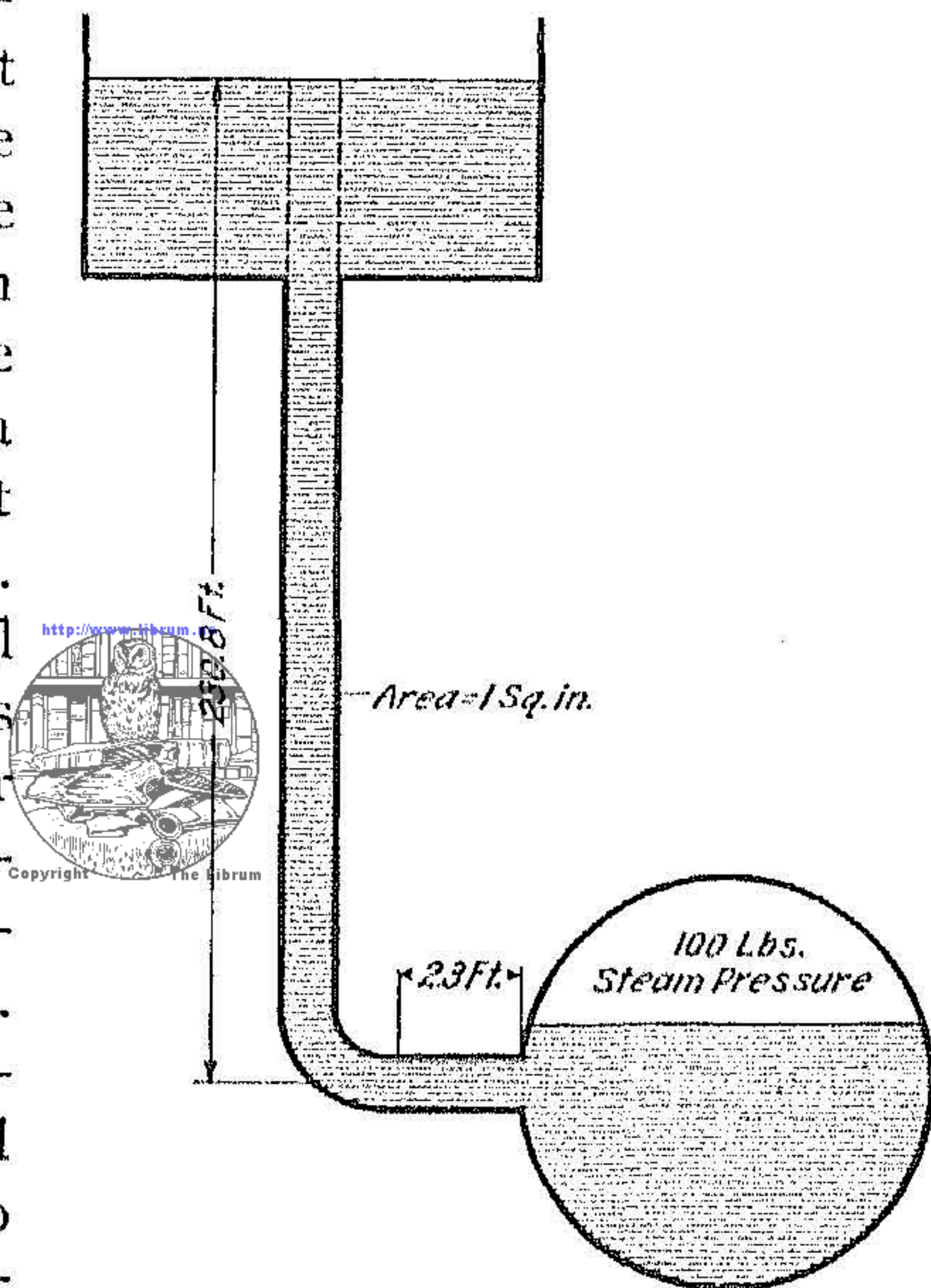

FIG. 1

6. The method of calculating the work done in forcing one pound of water into the boiler can be more readily understood by referring to Fig. 1, in which the boiler under a pressure of 100 pounds to the square inch is supplied with water through a pipe with an area of 1 square inch. The water reservoir with an inflow assumed to be just equal to the outflow to the boiler is elevated to such a height that the column of water exerts a pressure of 100 pounds on the check-valve, which has an area of 1 square inch. To exert a pressure of 100 pounds on the check-

valve, the column of water if at a temperature of 60° F. will be 230.8 feet high, so that 1 pound of water will be represented by a height of 2.308 feet. For every inch the column of water lowers by flowing to the boiler, an inch is added to the top of the column, so when 1 pound of water is transferred to the boiler, the column of water of a height of 230.8 feet moves down 2.308 feet. The number of foot-pounds of work performed by the water when it lowers this amount is equal to the weight of the water multiplied by the distance it lowers, or 100×2.308 , or 230.8, foot-pounds. The foregoing will be evident when it is remembered that the work expended in raising 1 pound of water 1 foot is 1 foot-pound, so that when the same weight of water is permitted to lower the same distance, an equal amount of work will be performed.

7. The following table gives the weight of a cubic foot of water at different temperatures and the head of water in feet corresponding to a pressure of 1 pound per square inch. With a boiler pressure of 200 pounds per square inch, the head of water will have to be twice as high and the foot-pounds of work done in putting one pound of water into the boiler will be twice as

TABLE I

HEAD OF WATER IN FEET CORRESPONDING TO A
PRESSURE OF ONE POUND PER SQUARE INCH

Temperature of Water Deg. F.	Weight of Cubic Foot	Head in Feet Equal to 1 Pound Per Sq. In.	Temperature of Water Deg. F.	Weight of Cubic Foot	Head in Feet Equal to 1 Pound Per Sq. In.
39.1	62.4250	2.3067	130	61.5320	2.3402
40	62.42398	2.3068	140	61.3432	2.3474
50	62.40735	2.3074	150	61.1413	2.3552
60	62.36975	2.3088	160	60.9266	2.3635
70	62.31015	2.3110	170	60.6988	2.3723
80	62.2283	2.3140	180	60.4608	2.3818
90	62.1253	2.3179	190	60.2128	2.3915
100	62.0033	2.3224	200	59.9569	2.4017
110	61.8626	2.3277	210	59.6935	2.4123
120	61.7053	2.3336	212	59.6400	2.4144

much, or 2.308 multiplied by 200, or 461.6 foot-pounds. Thus, the number of foot-pounds of work necessary to force 1 pound of water into the boiler is equal to the boiler pressure in pounds per square inch, gauge, times 2.308. This latter figure will vary slightly with the temperature of the feedwater. One British thermal unit is equivalent to 778 foot-pounds, hence the number of B. t. u.'s expended in putting 1 pound of water into the boiler under a pressure of 200 pounds is

$$\frac{2.308 \times 200}{778} = .5933 \text{ B. t. u.'s or about } \frac{2}{3} \text{ of 1 B. t. u.}$$

8. Next let it be assumed that it is desired to ascertain the number of B. t. u.'s required to deliver, say, 35,000 pounds of water per hour, against a pressure of 200 pounds, the temperature of the delivered water being 154° F. The calculation then becomes

$$\frac{2.355 \times 200 \times 35,000}{778} = 21,189 \text{ B. t. u.'s.}$$

The number 2.355 represents the height of a column of water at 154° F. required to exert a pressure of 1 pound. It requires a higher column of water to exert the same pressure, as the temperature is raised because of the expansion of the water.

The quantity of heat required to raise 35,000 pounds of water from 60° F. to 154° F. can be found as follows: The increase in temperature is 154 - 60 or 94 degrees. Each degree of increase per pound represents the expenditure of 1 B. t. u., hence it requires 35,000 × 94 or 3,290,000 B. t. u.'s to heat the water to the delivering temperature, so that for each B. t. u. expended in putting the water into the boiler, about 155 B. t. u.'s are expended in heating it. This is very wasteful, considering that the water can be heated by other means than by exhaust steam. The flow of water through the pipe and the check-valve creates considerable friction which has not been considered in the foregoing problem.

ELESCO FEEDWATER HEATING EQUIPMENT

DESCRIPTION

9. **Arrangement.**—The arrangement of the various parts of the Elesco feedwater heating equipment is shown in Fig. 2, which shows the recommended positions of the parts. The steam-operated pump is mounted on brackets riveted to the boiler shell and the heater in which the feedwater is heated by exhaust steam from the cylinders is mounted in advance of the smokestack. The suction pipe supplies the pump with water from the tender, the pump discharge pipe conducts the water under pressure to the heater, and the heater discharge pipe discharges the water through the check-valve into the boiler. The condensate that is formed from the condensation of the exhaust steam in the heater is returned to the tender through a condensate pipe, and the oil skimmer serves to remove most of the lubricating oil from the condensed water. The pump is operated by a pump throttle in the cab, which controls the flow of steam through a pipe to the pump; a heater pipe is used to convey steam to the suction pipe for heating the water and preventing it from freezing in cold weather. Exhaust steam from the air compressors and the feedwater pump is conducted to the heater through the piping shown.

10. **Operation.**—The operation of the Elesco feedwater heating equipment can be more easily understood from the simple diagram shown in Fig. 3. The admission of steam to the pump, following the opening of the pump throttle, causes the steam pistons to move up and down, thereby imparting a similar movement to the water pistons. Any air in the water cylinders is expelled and the partial vacuum that results causes atmospheric pressure to force water from the tender to the pump. From the pump, the water is forced through a pipe *a* to the heater, where it passes through a series of small tubes surrounded by exhaust steam from the cylinders. In these tubes much of the heat of the exhaust steam is transferred to the feedwater before it enters the delivery pipe *b* leading to the boiler. The condensation that occurs from the contact of the exhaust steam with the cold heater



1—Pump Throttle Valve
2—Steam Pipe

3—Heater Valve
4—Heater Pipe

5—Suction Pipe
6—Condensate Return Pipe

7—Oil Skimmer
8—Pump

9—Pump Discharge Pipe
10—Pump Exhaust to Heater

11—Discharge Pipe to Boiler
12—Locomotive Exhaust to Heater

13—Heater
14—Lubricator Connection

15—Cab Gauge Pipe
16—Squirt Hose

FIG. 2

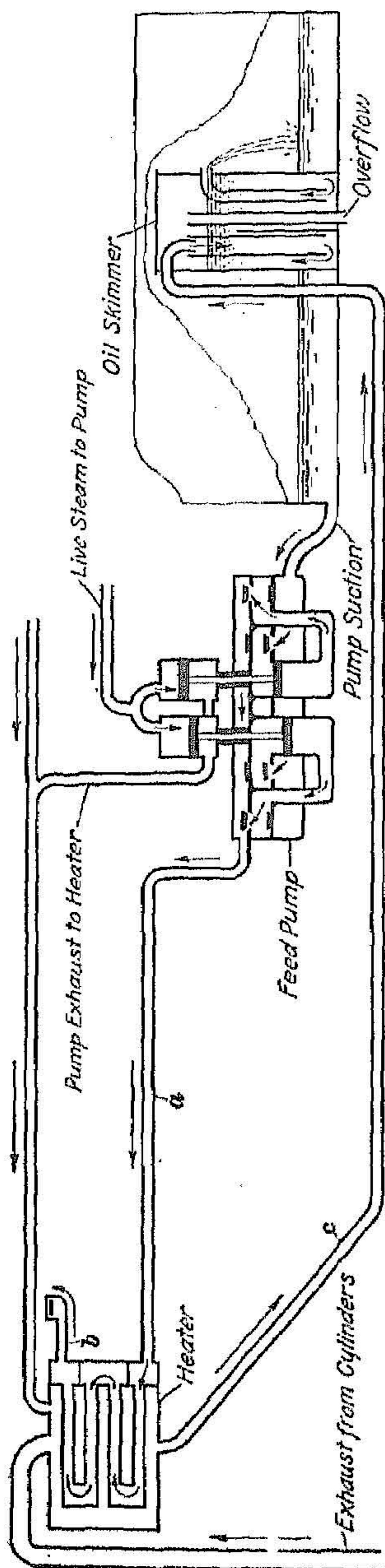

tubes is returned by gravity through the condensate line *c* to the tender, where the oil skimmer removes the lubricating oil.

FEEDWATER HEATER

11. **Description.**—The Elesco feedwater heater is a cylindrical-shaped device about 5 feet long and 2 feet in diameter and its purpose is to heat the cold feedwater with the exhaust steam from the cylinders. It may be considered as being made of two main parts, namely, an assembly of tubes between two tube plates, known as a tube bundle, and through which the water is pumped, and an outer shell or body with flange connections for the exhaust steam and other pipes.

In Fig. 4, the nuts have been removed from their studs and the tube bundle *a* with the headers *b* is shown partly withdrawn from the body *c*. Only one of the tube-sheets *a*, Fig. 5, of the tube bundle is bolted to the end of the heater; the tube-sheet *b* at the other end, on account of the variation in the expansion of the copper tubes and the steel shell of the heater, is free to move and is sometimes called the floating end. This end of the heater is closed by a casing *c*, Fig. 5.

The water inlet and the water outlet, Fig. 4, and the conden-

sate pipe connection *j*, Fig. 5 (*a*), as well as the exhaust steam-pipe connections *k* are located on the body of the heater as shown. The headers *d* and *e* that are bolted to the tube-sheets compel the water to make the proper number of passes through the tube bundle of the heater. On its way to the boiler, the water passes back and forth through the heater twice, so that it travels four times the length of the tube bundle.

With the locomotive in operation, the heater fills with exhaust steam from the cylinders and so surrounds the tubes of the tube bundle and heats the water that is flowing through them on its way to the boiler.

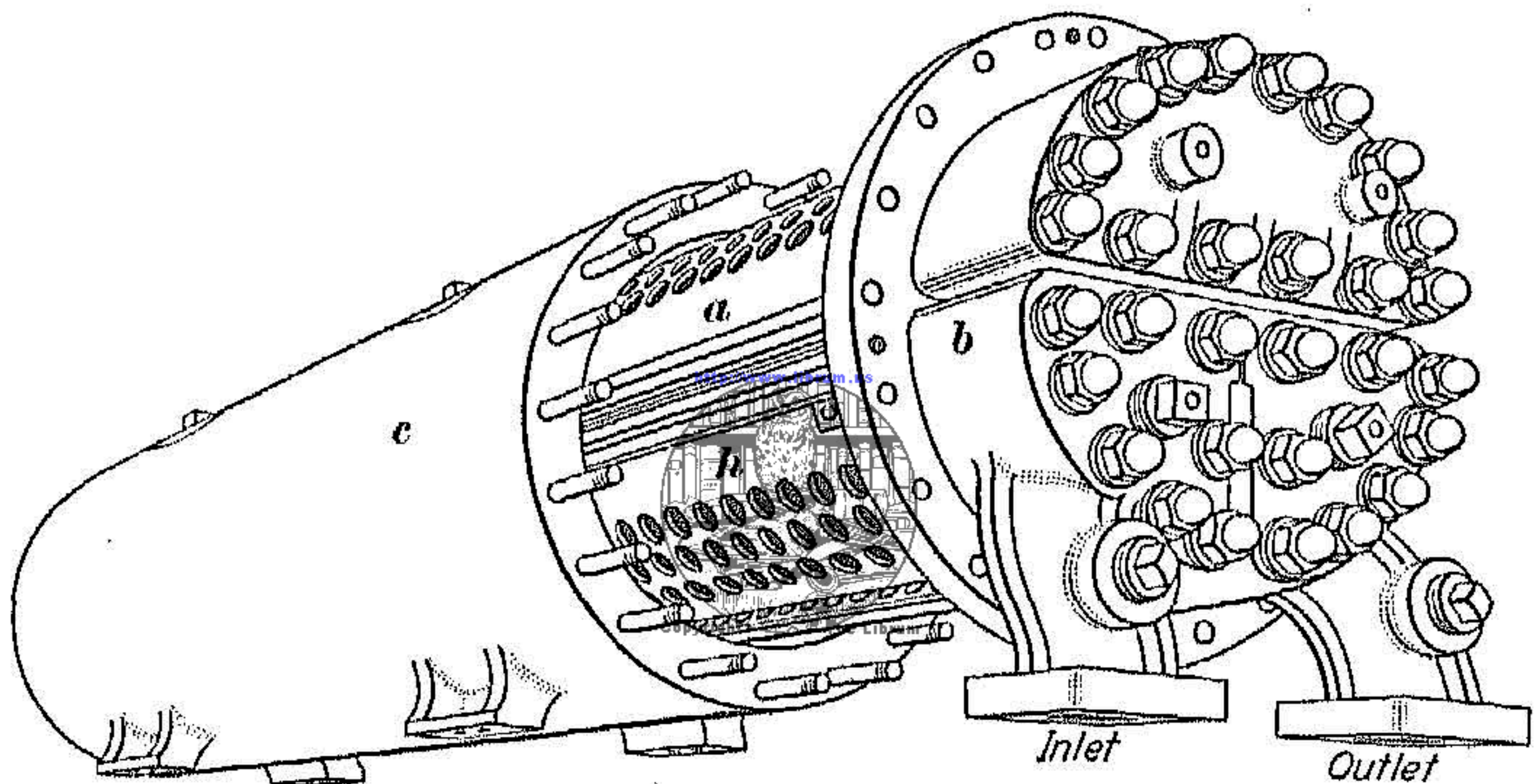
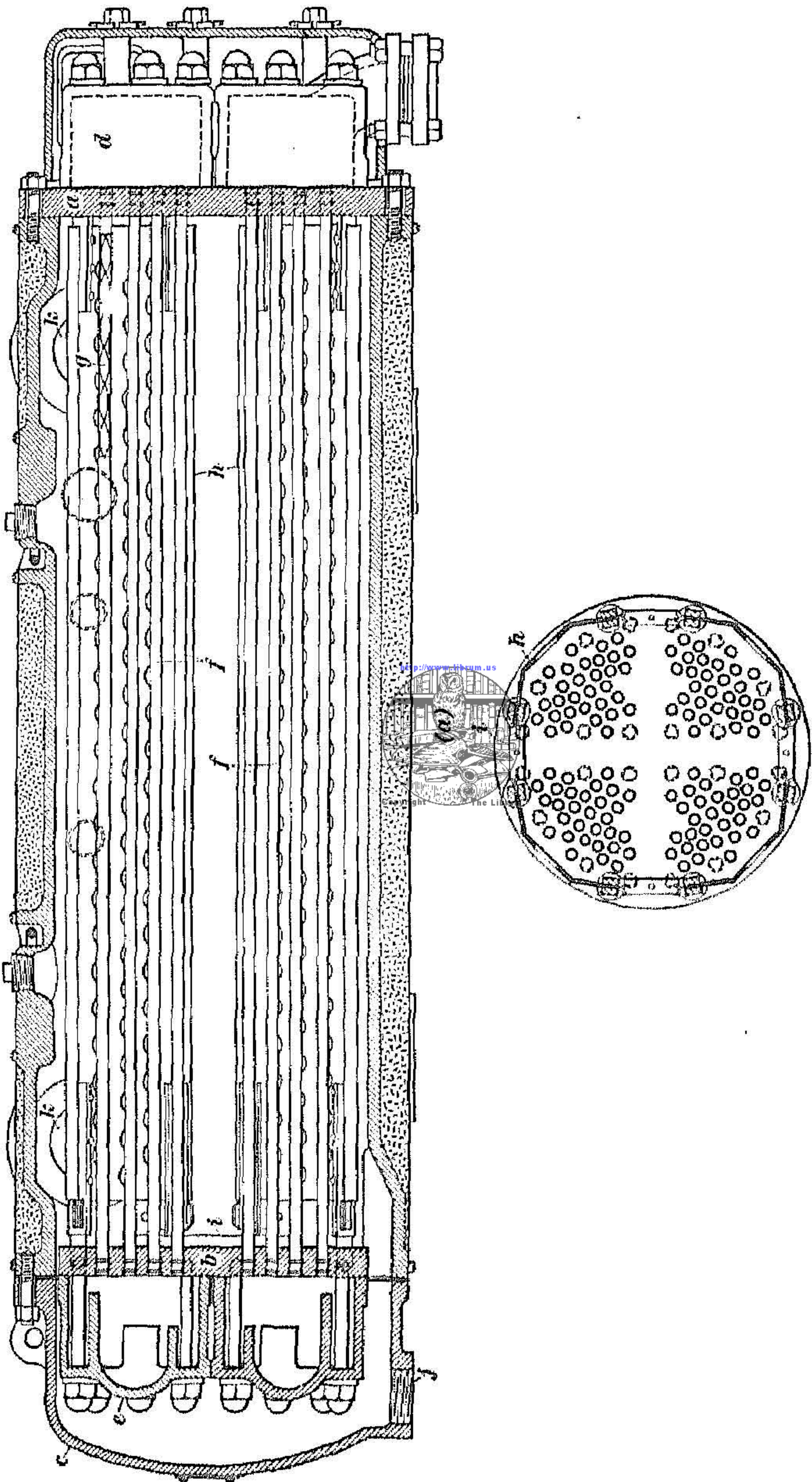

FIG. 4

12. **Tube Bundle.**—The tube bundle, Fig. 5 (*a*), comprises a large number of copper tubes *f*, supported by the tube-sheets *a* and *b*, to which the headers *d* and *e* are bolted. The tubes are secured at the ends to the tube plates by a special steam-tight grooved and tapered joint. As already stated, the tube-sheet at one end is bolted to the body of the heater; the other tube-sheet is free to move within the body and hence is called the floating tube-sheet or plate. Each tube contains a corrugated spiral copper strip *g*, called an agitator, the purpose of which is to mix up the water as it passes through the tube, thus insuring an even heat. The tubes are protected or shielded by a series of guard plates *h*, view (*b*), (also see Fig. 4) placed around them and held together around the tube bundle by the links *i*. The guard



(b)
FIG. 5

plates are perforated with large holes as shown, so as to permit of a free circulation of exhaust steam around the tubes.

13. Headers.—The complete tube bundle is divided into four groups or quarters, Fig. 5 (*b*), with spaces between them. The headers *d* and *e*, Fig. 15 (*a*), are belled out to form compartments, each of which is encircled by flanges and gaskets so that the compartments are kept separate when the headers are applied to the tube-sheets. A header that encloses one of the four groups

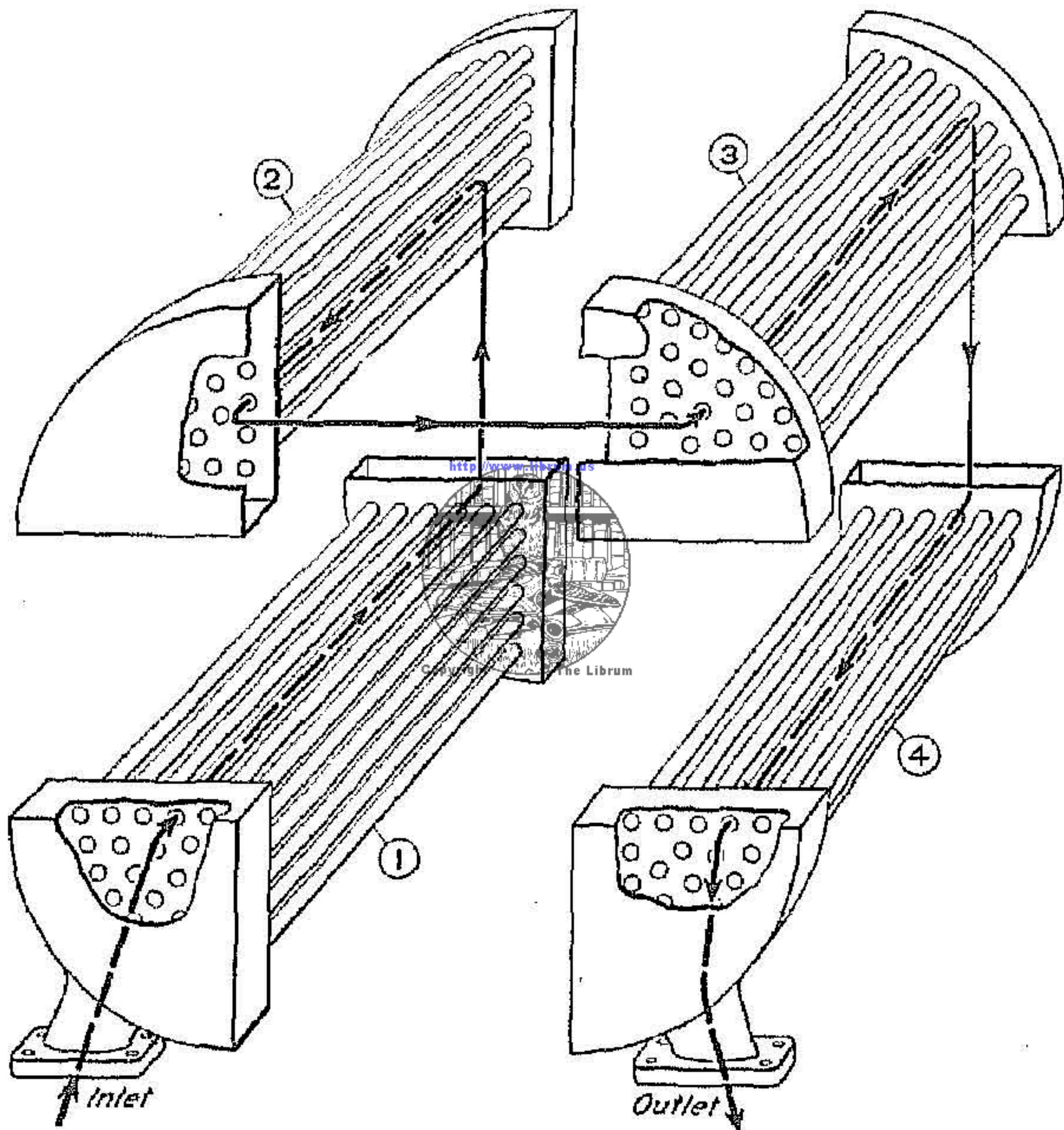
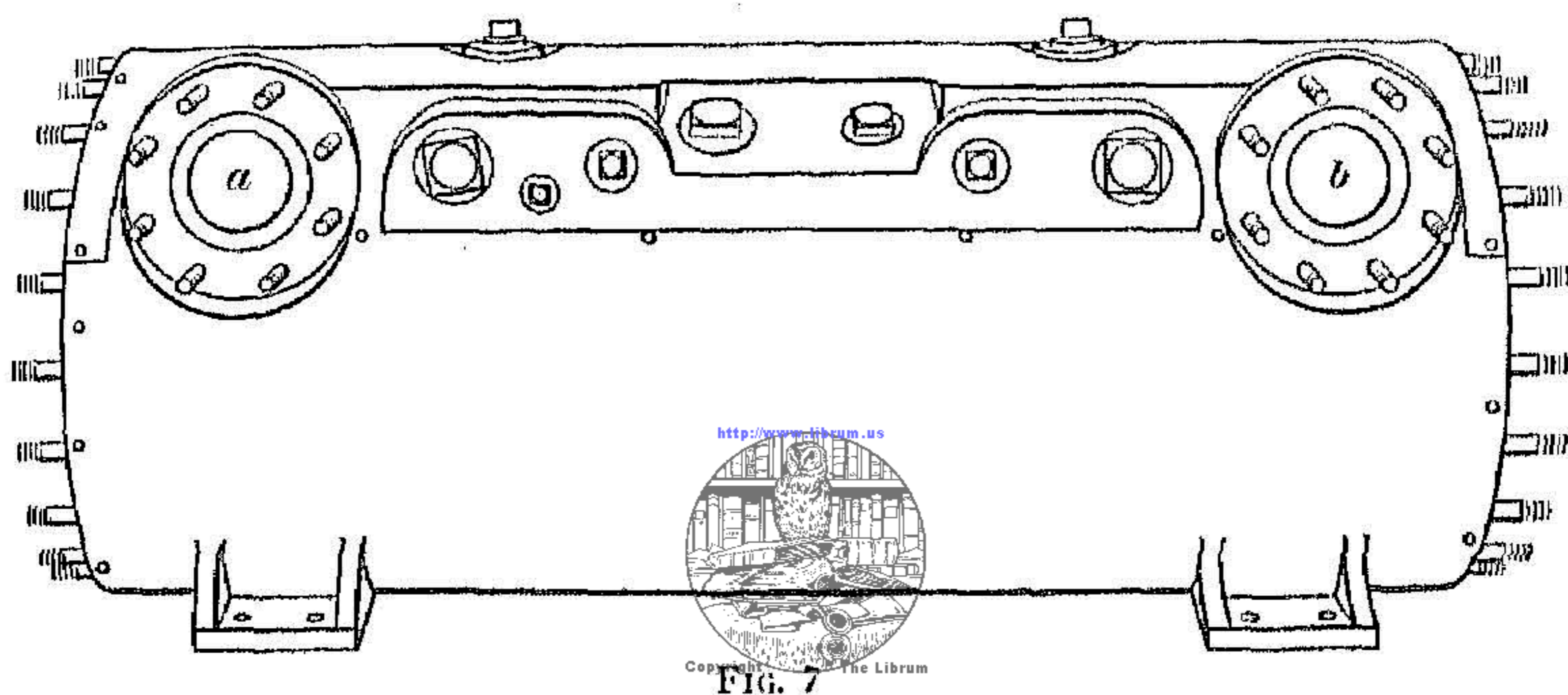

FIG. 6

or one nest of tubes of the tube bundle is known as a quarter-header, and one that takes in two groups of tubes is called a half-header.

The header arrangement on the heater depends on the direction or the angle of approach of the feed-water pipes. When the half-header on the main end is horizontal, then the two half-headers on the floating end must be vertical. When the half-header on the main end is vertical, the two half-headers on the floating end must be horizontal.

As already mentioned, the headers compel the water to make four passes through the heater before entering the discharge pipe. Thus, in Fig. 6 the water is discharged by the pump into a quarter-header and the group of tubes marked 1, and passes through to the half-header at the far end, which connects groups 1 and 2. The water then passes back through group 2 to a half-header at the near end, which connects groups 2 and 3. Next, the water flows through group 3 to the far end and passes through another half-header at this end to group 4, and thence to a quarter-header at the near end, whence it flows to the boiler.



The floating tube-sheet does not make a tight fit in the heater body, hence the exhaust steam also surrounds the two half-headers at this end. The condensate that forms from the condensation of the steam is drained into the floating header casing, where it passes through the pipe connection *j* shown in Fig. 5 (*a*) and is carried by gravity by the condensate return to the tender.

14. **Body.**—The body or exterior part of the heater is a cast-iron cylindrical-shaped casting that contains two large pipe-flange connections *a* and *b*, Fig. 7, for the pipes used to convey the exhaust steam from the cylinders and several reinforced pipe-tapped holes for the pump and compressor exhaust-pipe connections. Each end of the body is machine-faced, and holes are drilled and tapped out for studs used to secure the fixed tube-sheet to one end and the floating header casing to the other. All exposed surface of the body is covered with insulation to prevent

radiation of heat, and a sheet-metal jacket is applied over the insulation to keep out moisture and to provide a surface that can be painted.

PUMP

15. **Description.**—The purpose of the pump is to draw water from the tender and force it through the heater and thence into the boiler. An exterior view of a CF-1 type of pump is

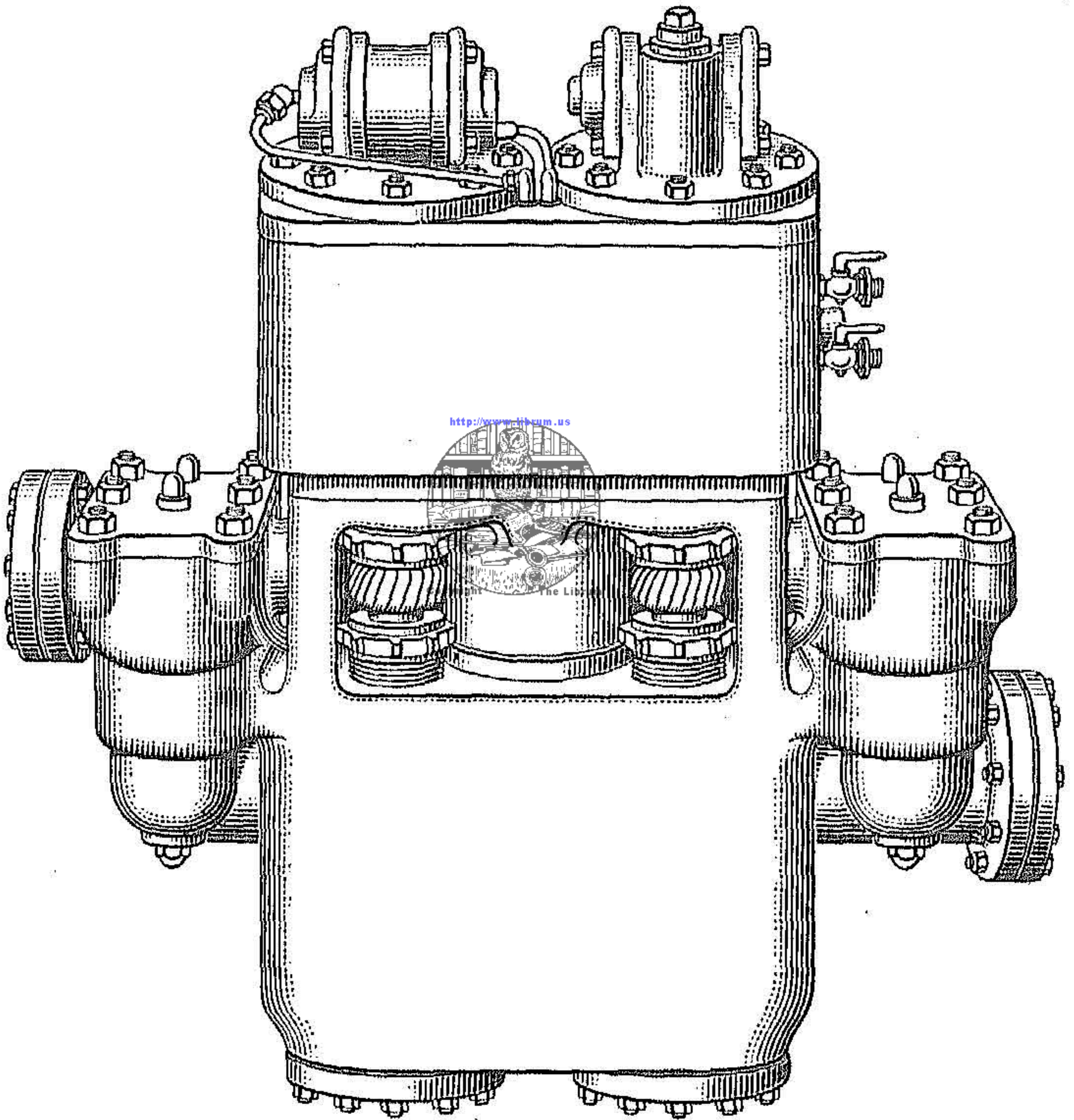

FIG. 8

shown in Fig. 8, and in Fig. 9 is shown a sectional view with the valves arranged to make the operation more evident. Actually the water valves are placed one behind the other. At *a* the water is drawn into the pump from the tender and is discharged at *b*, it being assumed that the pump is mounted on the left side of the boiler. The pump comprises two separate pumps, each

one acting independently of the other. In some types one pump is controlled by the other. Each pump has a steam cylinder and a water cylinder and is double-acting, that is, water is pumped on both strokes. The steam piston in the upper cylinder operates a water piston in the lower cylinder, and as the valve mechanism of each of the upper cylinders corresponds exactly to that of the Westinghouse $9\frac{1}{2}$ -inch air compressor, no further description of the steam end is required.

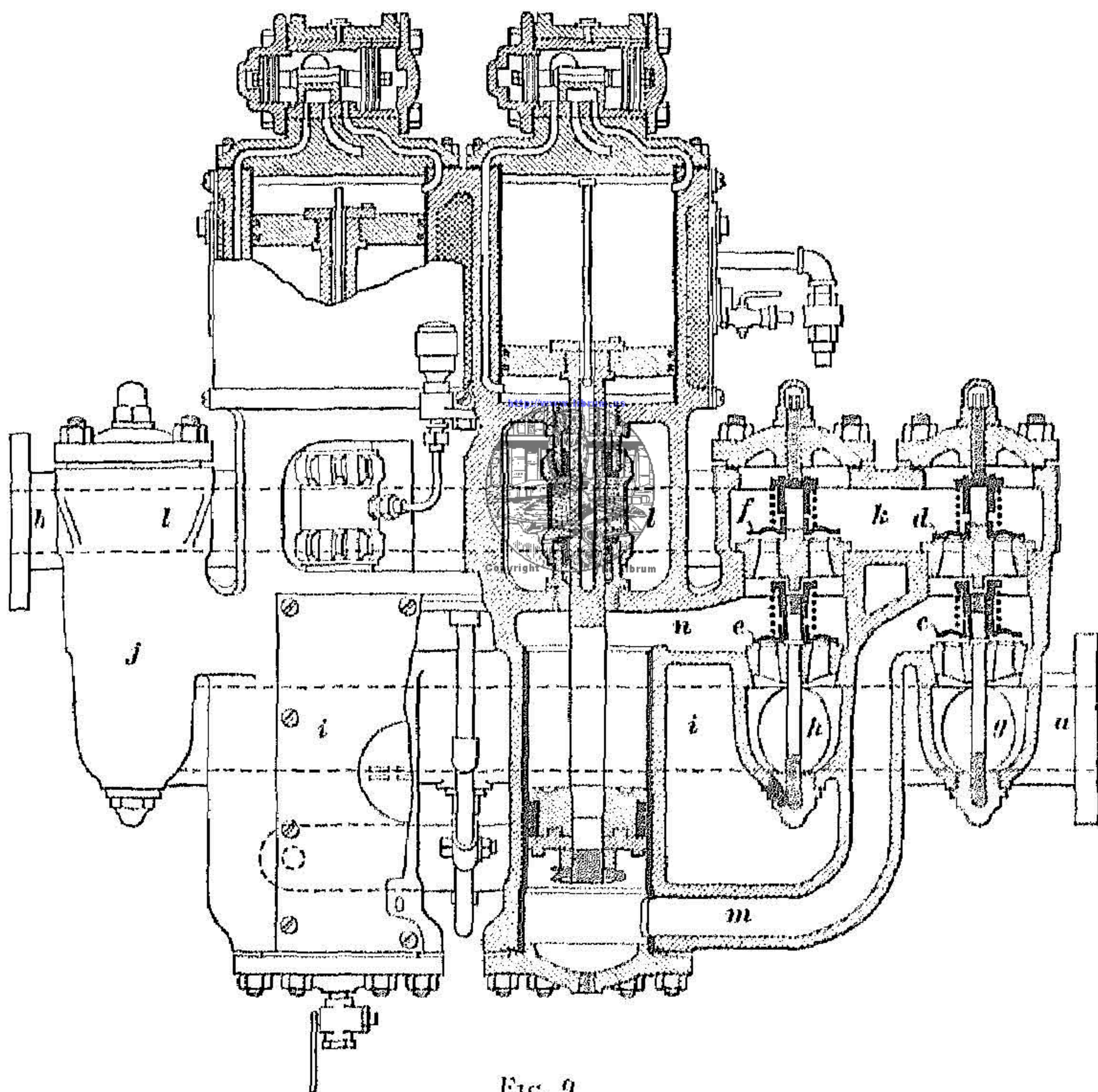

FIG. 9

The lower end of the water cylinder is furnished with an inlet valve *c* and a discharge valve *d* and the upper end is similarly equipped with an inlet valve *e* and a discharge valve *f*. The chambers *g* and *h* below the inlet valves are in communication through the openings shown to the inlet passage *i*, which, as shown by dash lines, leads across the pump to the two inlet valves

in the casing *j* for the water cylinder on the other side of the pump. The chambers *k* above the discharge valves communicate with a passage *l*, also shown by dash lines, which leads to the space above the discharge valves on the opposite side of the pump and to the discharge-pipe connection *b*. The arrangement of the inlet and the discharge valves in the case *j* are the same as just described. The water cylinders are lined with renewable bronze bushings, and the piston rod connecting the two pistons is made steam-tight by means of a stuffingbox, the packing, and a nut on both the steam and the water cylinders. Both pistons are also supplied with suitable packing rings.

16. Operation.—On the upward stroke of the water piston, a partial vacuum forms in the lower end of the cylinder. The pressure of the atmosphere on the surface of the water in the tender then forces the water through the suction pipe, raises the valve *c*, Fig. 9, and passes through passage *m* to the lower end of the water cylinder. On the downward stroke of the water piston, the inlet valve *c* closes by its weight and the pressure of the water; the discharge valve *d* then rises and the water is forced out to the discharge passage *l* and thence through the discharge pipe to the heater and the boiler. As the piston descends, the water is drawn into the upper end of the cylinder through the inlet valve *e* and passage *n* and on the return stroke is discharged through the discharge valve *f* to chamber *k* and passage *l* to the heater.

With both pistons in operation, there are always two inlet valves and two discharge valves unseated. This causes a steady flow of water through the heater and also through the check-valve, so that it is kept open and is given little opportunity to hammer on its seat unless both pumps reverse simultaneously. The amount of water delivered to the boiler is dependent on the speed of the pump.

OIL SKIMMER

17. Purpose.—A considerable quantity of water can be saved by returning the condensate from the heater to the tank; this is an important item where high-speed traffic is concerned. However, before this water can be used again, the lubricating

oil must be removed; otherwise it will cause the water in the boiler to foam. The oil skimmer is designed to remove the oil before the condensate is permitted to mix with the water in the tender.

18. **Operation.**—The condensate enters the skimmer at *a*, Fig. 10 (*a*) and is conveyed to a point near the floor of the tank, where it flows out into the first compartment *b*. The oil *c*, being lighter than the water, rises to the top of the water in the skimmer. The clear water flows over the partition plate *d* to the bottom of the overflow pipe *e*, through which it leaves the

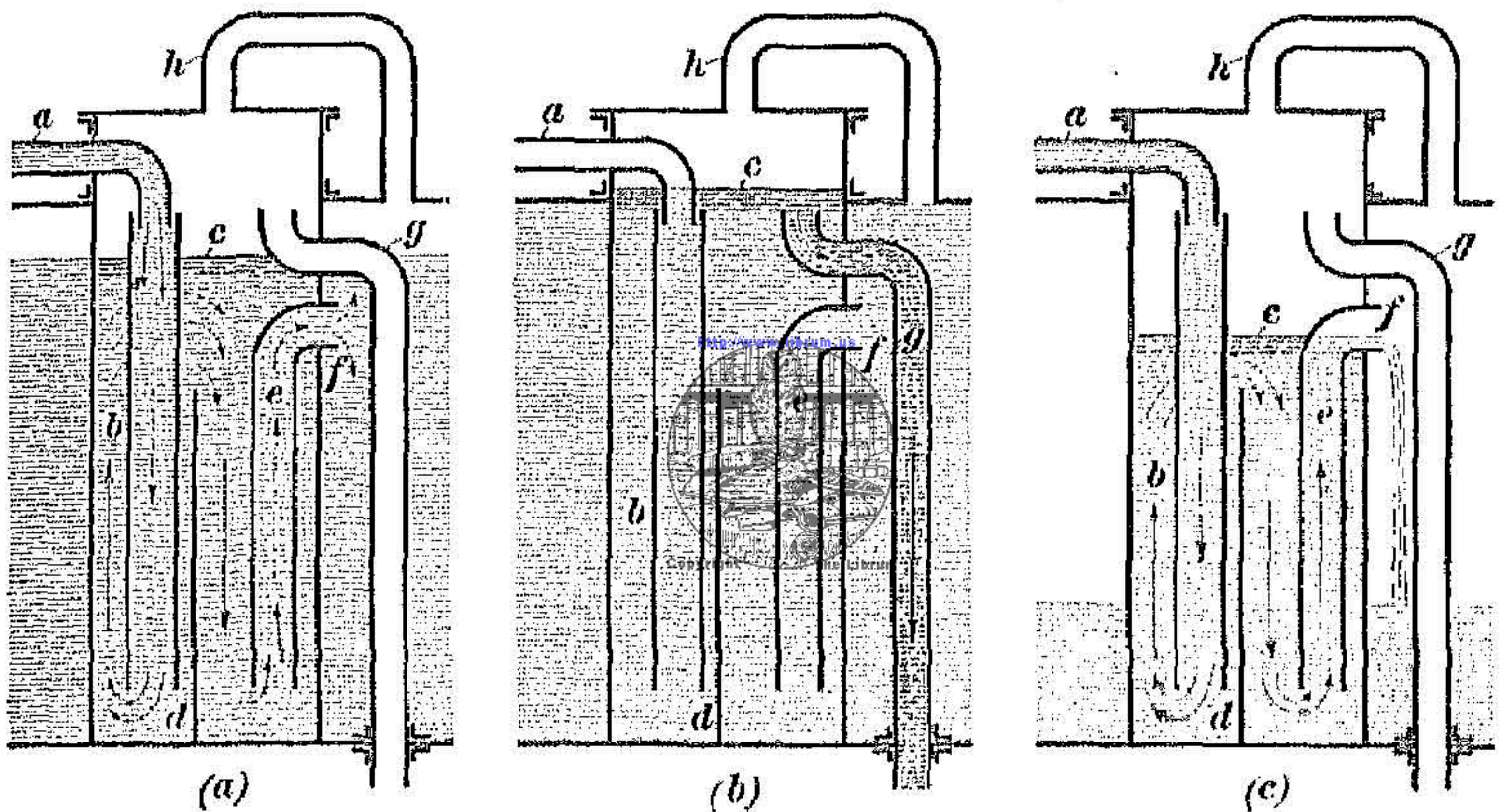

FIG. 10

skimmer at *f* and mixes with the other water in the tender. When the water level is at a maximum, as when the tank has been filled to capacity, view (*b*), the water from the tank enters the skimmer at *f* and raises the oil up far enough to flow out through the oil overflow pipe *g*. This is the only time when the oil flows out of the skimmer; at other times it remains trapped. In the event of the water being low in the tender, the water level in the skimmer cannot sink below the mouth *f* of the overflow pipe *e*, as shown in view (*c*). This insures that no oil is permitted to escape from the trap. A drain pipe should be placed in the bottom of each compartment so that the skimmer may be drained and damage prevented when the engine is stored in

severe weather. The pipe *h* serves to maintain atmospheric pressure in the skimmer.

19. **Condensate-Return Tank.**—When the heater is located at such a low elevation, as on the pilot, that the water will not drain back to the tender by gravity, a condensate-return tank is necessary. The condensate drains into this tank and is forced out by air pressure admitted from the main reservoir. A condensate trap is installed below the cab where the condensate discharge is connected to the pump suction pipe.

WORTHINGTON TYPE BL FEEDWATER HEATING EQUIPMENT

GENERAL DESCRIPTION

20. The Worthington feedwater heater is of the open type, whereas the Elesco heater is of the closed type. The exhaust steam with an open heater mingles directly with the feedwater; with a closed heater the exhaust steam does not come into direct contact with the water, the steam and the water being separated by tubes.

The arrangement of the Worthington feedwater heater apparatus is shown in Fig. 11. The principal part of the apparatus is a heater, the type BL being shown, which is made up of a cold-water pump, a heater, and a hot-water pump, with a steam cylinder for the operation of both pumps, the complete assembly being contained in a casting attached to the side of the boiler. An exhaust-steam pipe in which is installed an exhaust-steam check-valve, conveys exhaust steam from the cylinders to the heater compartment of the feedwater heater. A suction pipe leads from the tank to the cold-water cylinder of the pump and a discharge pipe leads from the hot-water pump to the boiler check-valve. The cab equipment comprises a pump throttle, an indicator gauge to show the speed at which the pump is working, and a connection to the lubricator. Other details will be evident from the illustration.

<http://www.librum.us>



Copyright © The Librum

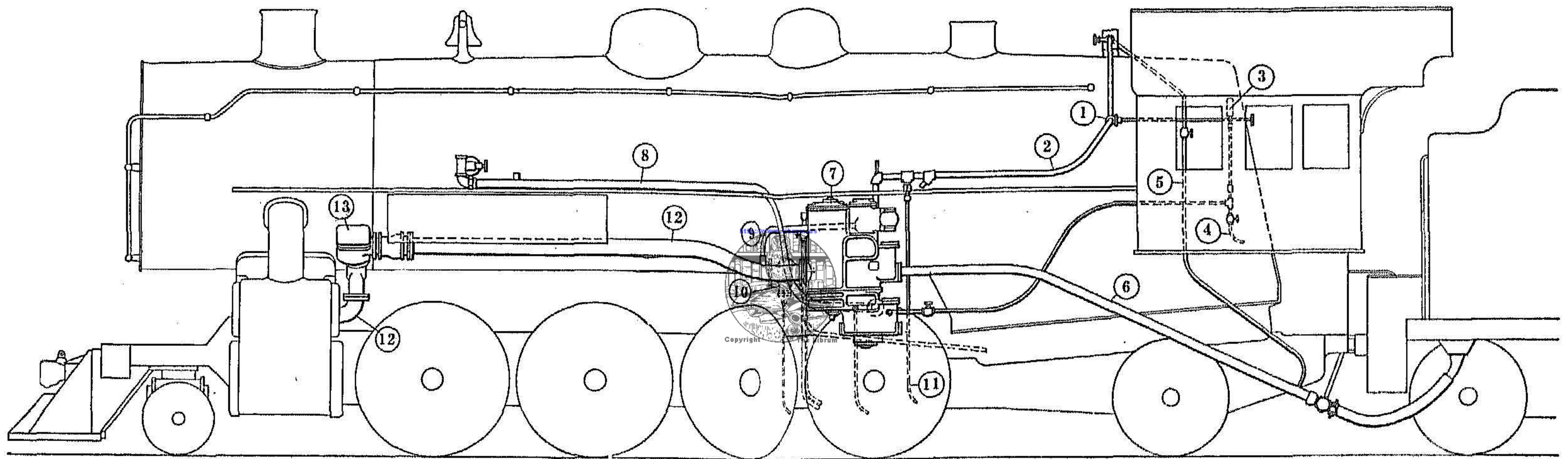

1—Pump Throttle Valve
 2—Pump Steam Pipe
 3—Cab Gauge
 4—Squirt Hose

5—Suction Heater Pipe
 6—Suction Pipe
 7—Feed Pump and Heater

8—Delivery Pipe
 9—Pump Exhaust Pipe
 10—Oil Separator

11—Pump Steam Line Drain
 12—Exhaust Steam Pipe
 13—Exhaust Steam Check-Valve

<http://www.librum.us>



Copyright © The Librum

TYPE BL LOCOMOTIVE FEEDWATER HEATER

21. **Operation.**—An exterior view of the type BL feedwater heater is shown in Fig. 12 and a sectional view is shown in Fig. 13. The piston in the steam cylinder operates the piston

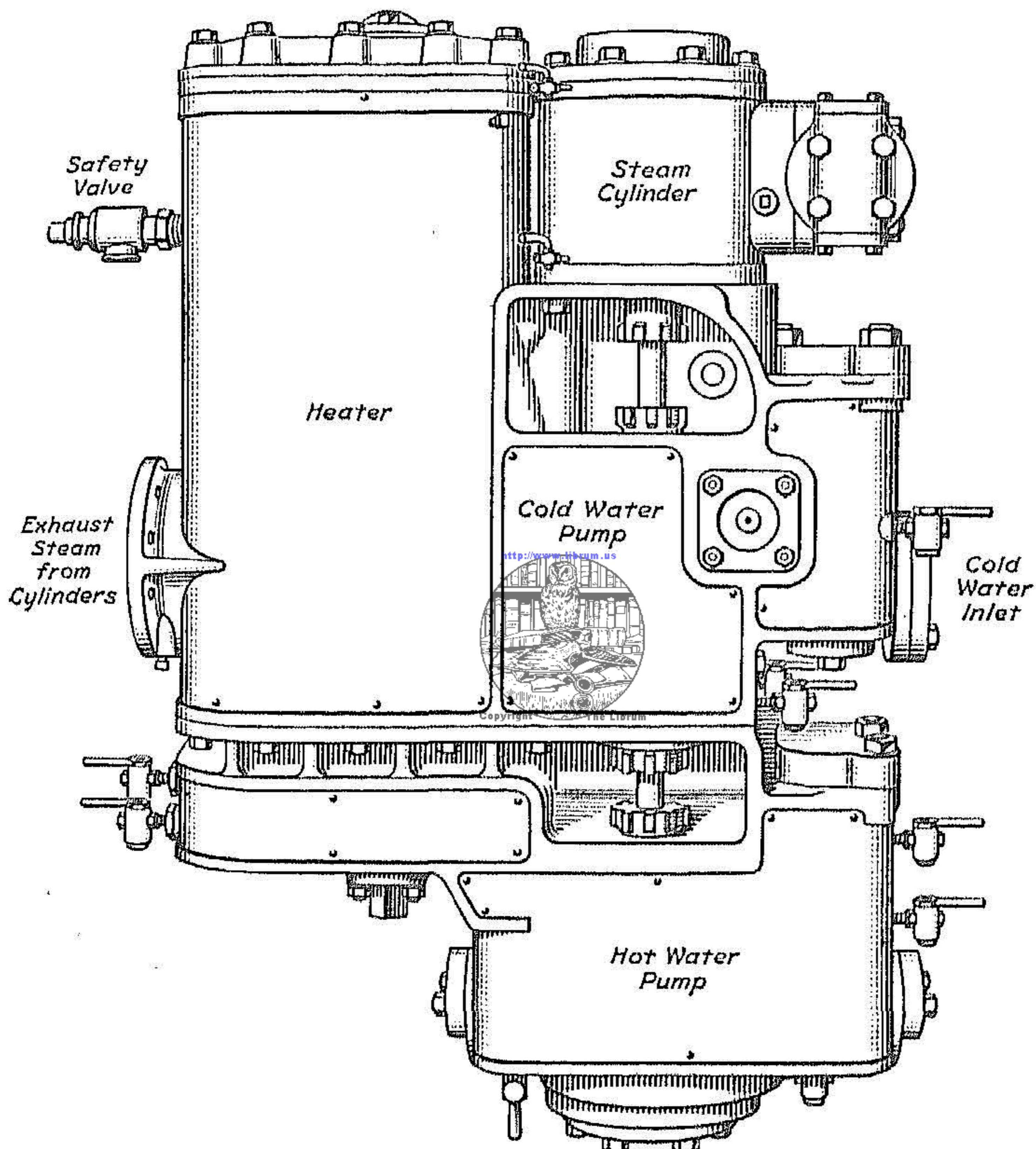

FIG. 12

in the cold-water cylinder and also one in the hot-water cylinder, all of the pistons being on the same rod. Each end of the cold-water cylinder has at least one suction valve and one discharge valve; the larger pumps have several of each. The same applies to the hot-water cylinder. The cold-water cylinder draws the water from the tender and delivers it to the heater, from whence it is drawn by the hot-water pump and delivered to the boiler.

On the downward stroke of the piston, water enters the cold-water cylinder through the suction valve *a* from the suction pipe and is forced out through the discharge valve *b* to a pas-

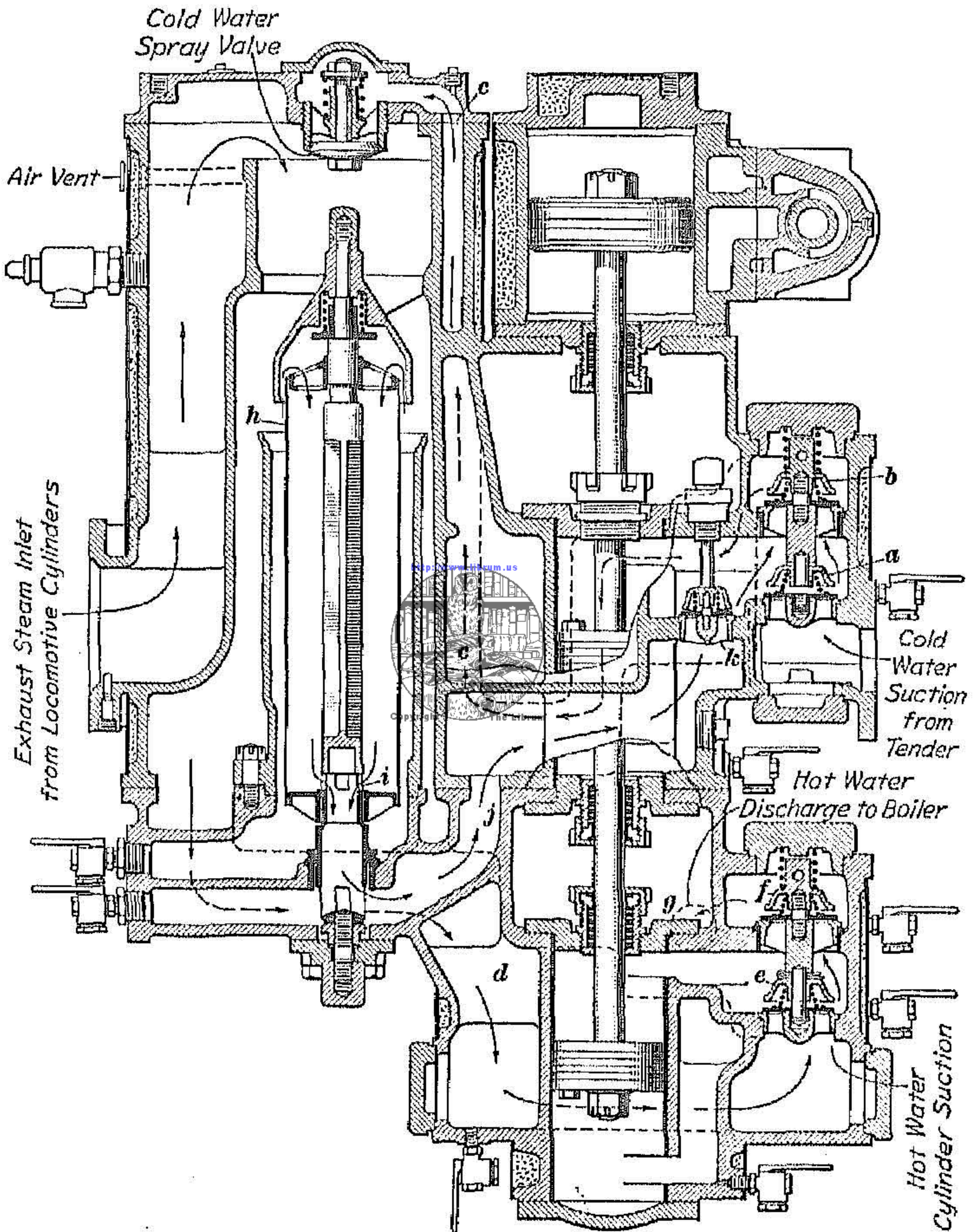

FIG. 13

sage *c* that leads to the cold-water spray valve. The water is forced through the valve and emerges in the form of a spray to the upper part of the heater compartment, which is supplied with exhaust steam from the cylinders. Much of the heat of the exhaust steam is absorbed by heating the water and the exhaust

steam then chills and condenses. The water, including the condensate, falls to the bottom of the heater chamber and then passes through the passage *d* to the hot-water cylinder, whence it is drawn in through the suction valve *e* and forced out through the discharge valve *f* and passage *g* to the boiler. The pump is double acting; the valves that operate on the upward stroke are behind the valves shown and cannot be seen.

22. Both water cylinders are of the same size, so both handle about the same amount of water but, owing to the condensation of the exhaust steam, the hot-water pump is called upon to discharge more water than the cold-water pump brings in to the heater. This the hot-water pump cannot do and as a result an excess of water accumulates in the heater. The floating bucket *h* is designed to take care of this condition. This bucket floats in the water in the heater and the falling water from the spray valve is prevented from passing directly into the bucket by the head or cap shown. When the water, as it rises, floats the bucket to its extreme upward position, the water flows over the top and loads the bucket down, causing it to sink. This action causes the ports *i* in the stem to open and permits the water to flow out of the bucket into passage *j* to the return valve *k*, where the water is pumped out by the cold-water pump. This water mingles with the water from the tank and is passed up through and into the heater again; while this is taking place the flow of water from the tender is reduced. When sufficient water has been pumped out of the heater, the bucket becomes partially empty and again rises in the water and closes ports *i*; the cold-water pump then takes all of its water from the tender.

In heating and turning water into steam in the boiler, a certain amount of oxygen is liberated, or set free; this oxygen is harmful to the boiler, as it causes pitting and corrosion of the plates. When the water is heated before it enters the boiler, much of the oxygen set free is permitted to escape to the atmosphere through an air vent in the heater, so that a large portion of the free oxygen does not find its way into the boiler. This lessens the tendency for the feedwater to corrode and pit the boiler plates.

AUXILIARY STEAM CYLINDER

23. Operation.—Diagrammatic views of the auxiliary cylinder as well as a portion of the main steam cylinder of the heater are given in Fig. 14 (*a*), (*b*), and (*c*). The auxiliary steam cylinder contains the auxiliary plunger *a* that actuates the slide valve *b* and two reversing valves *c* and *d*. The port arrangement is such that one of the reversing valves operates as the steam piston nears the end of its stroke and brings about its reversal. Steam pressure is always present in chamber *e* between the two heads of the auxiliary plunger; steam pressure is also maintained at the outer ends of the auxiliary plunger by way of the steam passages indicated, the reduced section of the reversing valves, and passages *f* and *g* with the piston anywhere in the cylinder except near the end of the stroke. Thus, in view (*a*) live steam from passage *h* passes to both the top and the bottom of the left auxiliary valve; exhaust steam also passes through passage *i* to the top and bottom of the right auxiliary valve, holding them both in their lower positions, thereby causing steam to be admitted to the outer ends of the auxiliary plunger.

24. As the steam piston nears the end of its stroke to the left, the steam piston, view (*b*), Fig. 14, opens port *j* and admits live steam under the upper end of the right-hand reversing valve, which is accordingly forced upwards as it has only exhaust steam on top. The valve now permits the steam to escape from the outer end of the auxiliary plunger through passage *k* to the exhaust, and unbalances the plunger; the pressure on the left end of the plunger then moves it and the slide valve to the right, view (*c*).

As soon as the slide valve reverses, live steam enters passage *l* and forces the right auxiliary valve downwards again, and the auxiliary plunger is once more balanced by the admission of steam through passage *f*. The piston, when nearing the end of its stroke to the right, opens port *l* and steam passes under the upper end of the left auxiliary valve. The valve is forced upwards and the steam exhausts through port *m* from the outer end of the auxiliary plunger, which then moves to the left. With

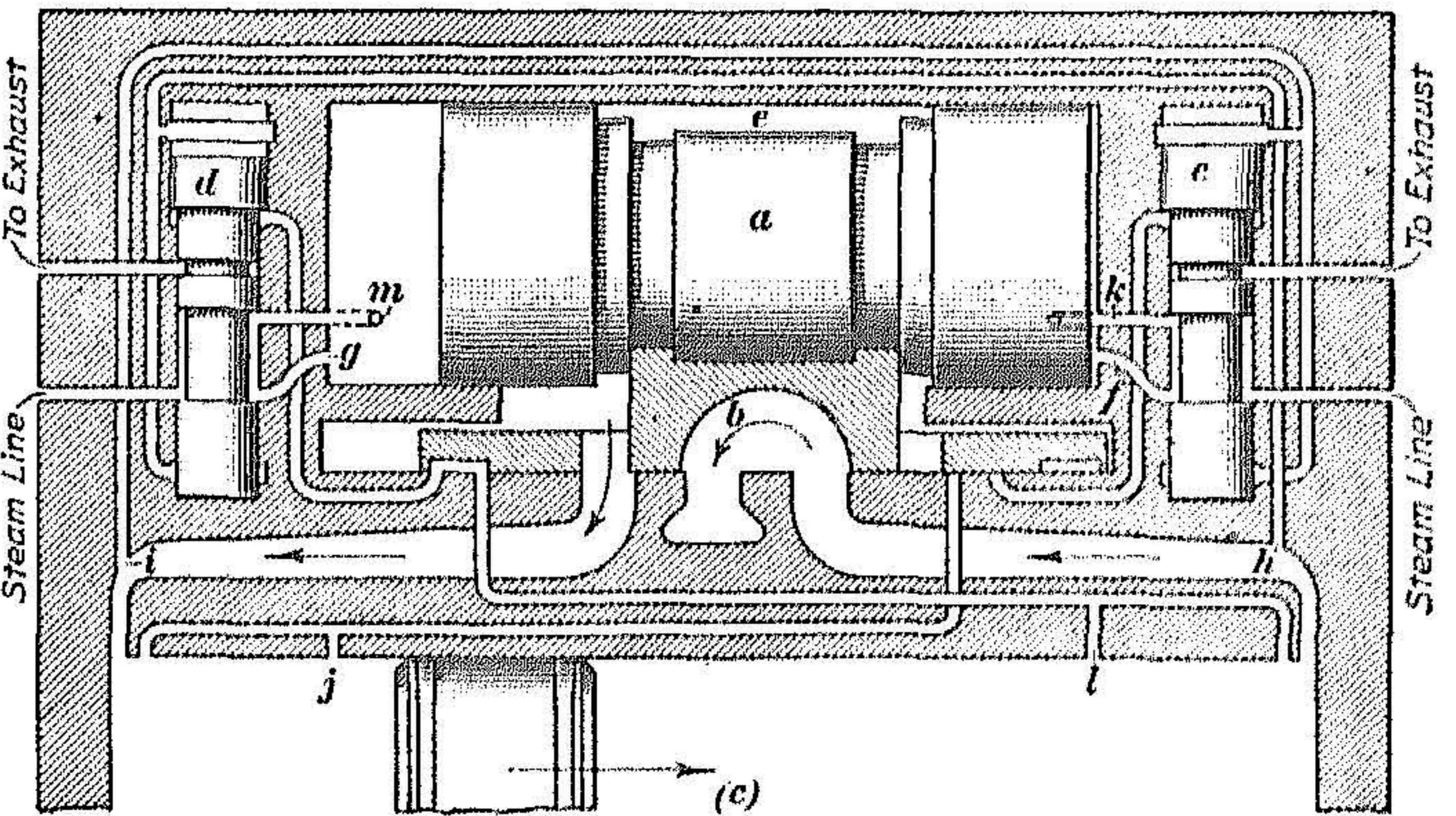
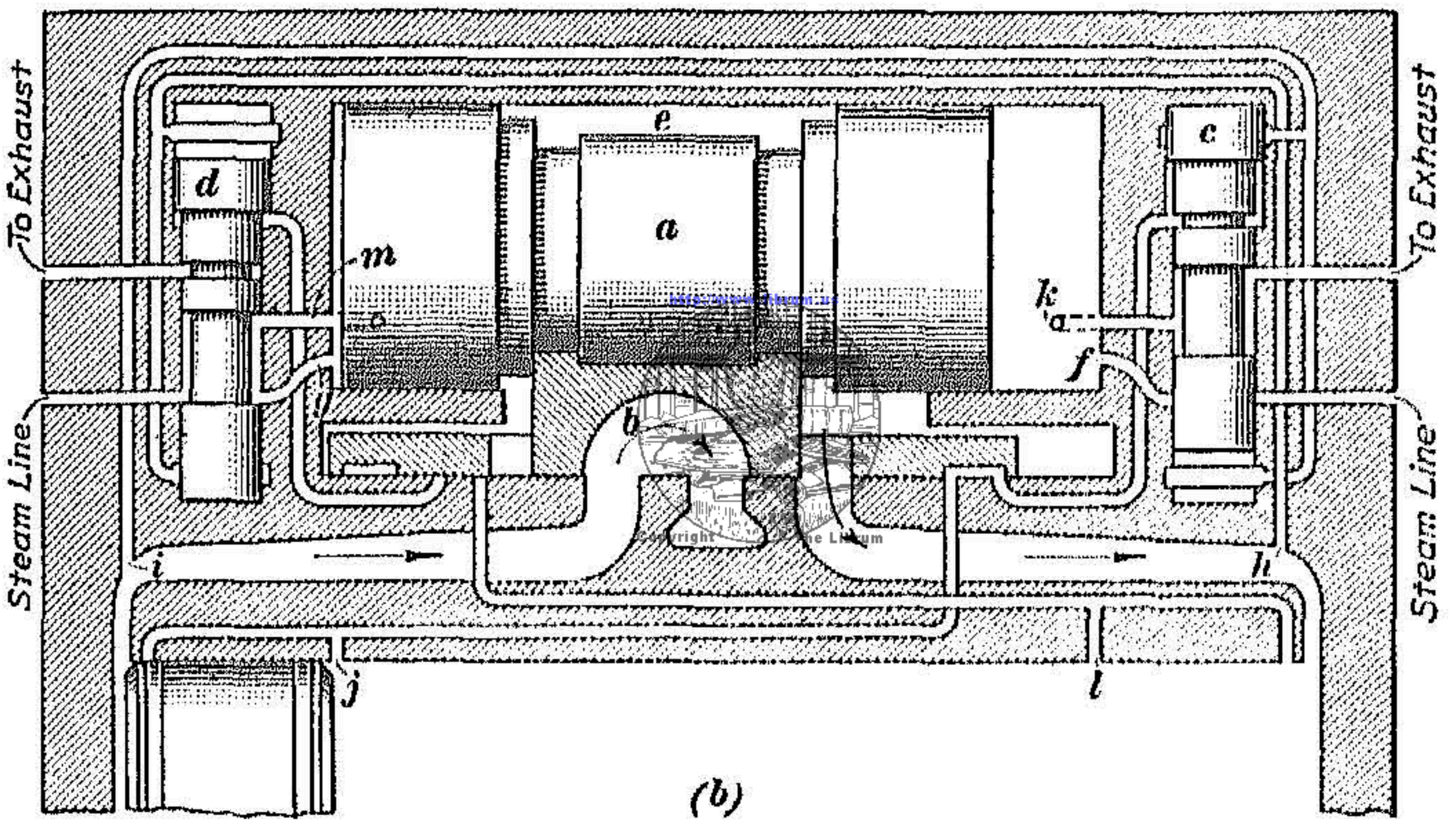
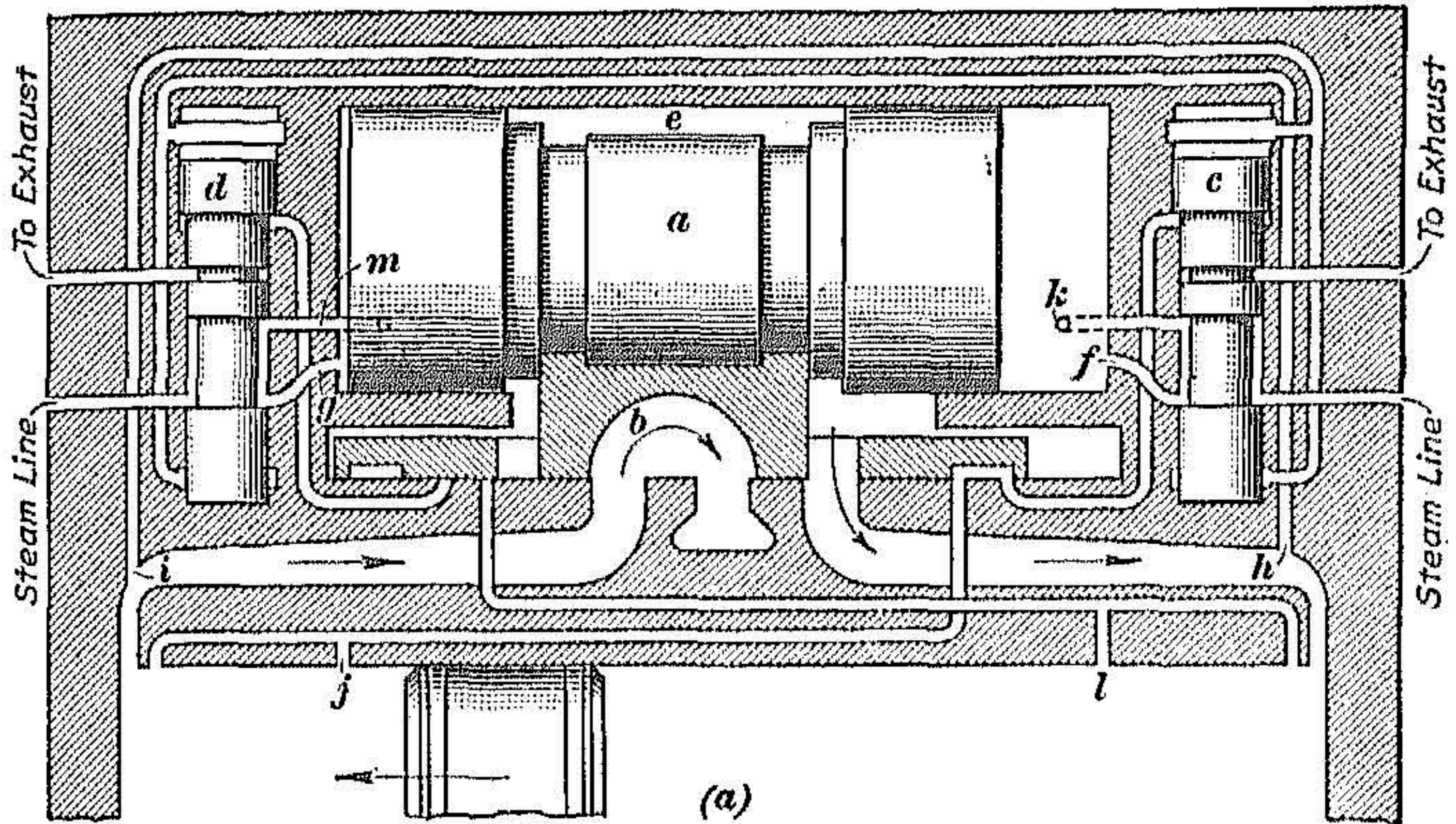

FIG. 14

the slide valve moved over to the left, live steam is admitted through passage *h* to the top of the left reversing valve and forces it down; steam then again passes to the left end of the plunger. To simplify the description and operation of the valve, the cavities that exist on each side of the valve *b* have been placed at the ends and the ports rearranged accordingly.

EXHAUST CHECK-VALVE

25. Purpose.—The purpose of the exhaust check-valve in the exhaust-steam line to the heater is to compel the exhaust steam from the feed pump to pass on to the heater instead of to

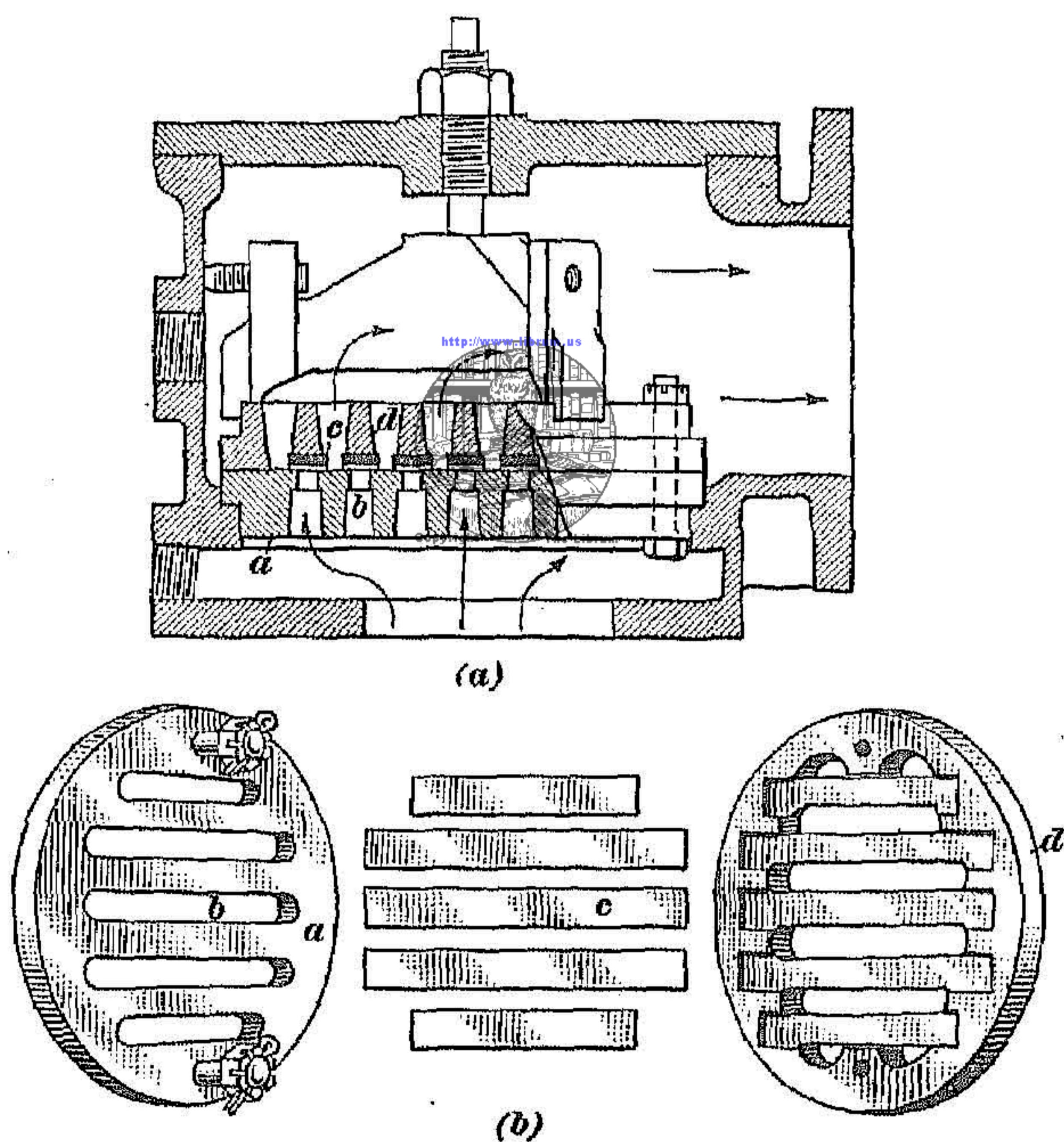

FIG. 15

the stack when the locomotive is drifting. It also prevents any flow of exhaust steam from the steam pipe in the reverse direction. As shown in Fig. 15 (a) the valve comprises a seat *a* with slots *b* to retain the valve strips *c*, and a guard *d* to prevent them from lifting too far out of their slots. These parts are shown disassembled in view (b). In the event of the removal of

this valve, extreme care should be taken when replacing it to see that the valve strips open in the direction of the flow of exhaust steam to the heater.

CAB GAUGE

26. The gauge in the cab is connected to the discharge pipe of the feed pump and indicates by a movement of its hand whether the pump is running and how fast, but not necessarily the water pressure in the discharge pipe. A three-way self-cleaning cock, Fig. 16, with a $\frac{1}{8}$ -inch passage through it is provided with the gauge. In the operating position, view (a), the water passes through this restricted opening, which reduces the throw of the hand to an amount that will not injure the gauge. In the cleaning position, view (b), the passage is connected to the atmosphere and the pressure of the water will then force out any obstruction and clear the port.

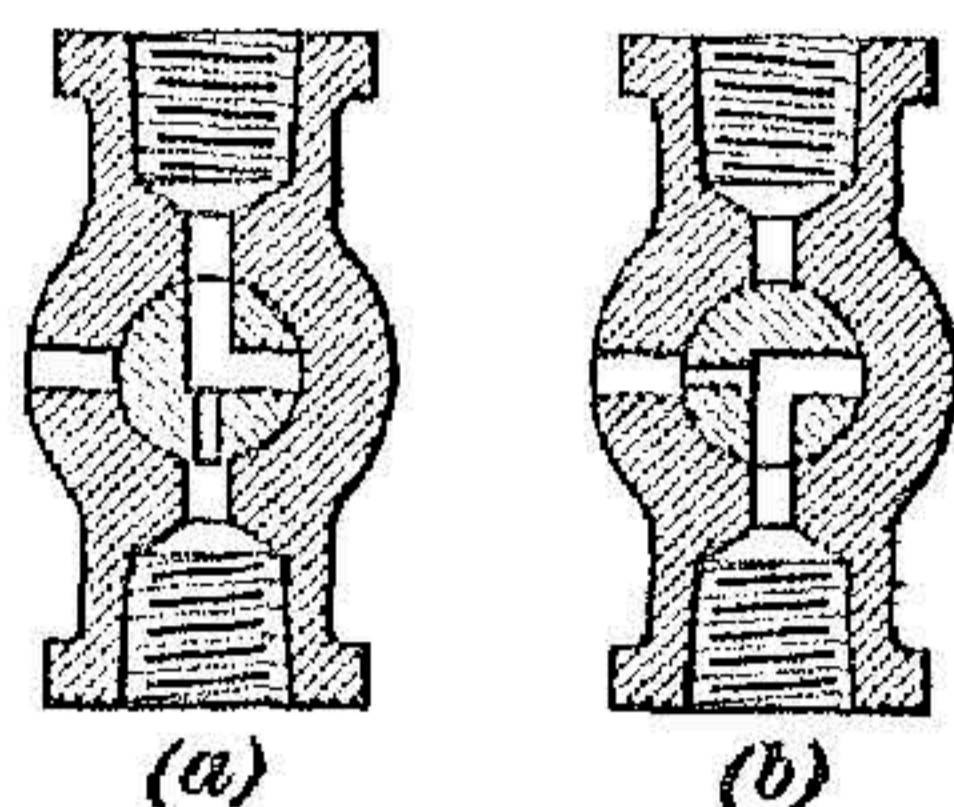

FIG. 16

27. **Operating Instructions for B and BL Feedwater Heating Equipment.**—The following instructions for the operation of the types B and BL feedwater heating equipment are issued by the manufacturer:

1. Make certain that the tank valve is *wide* open. Sometimes the handle does not correctly indicate whether the valve is wide open.
2. Start the pump lubricator 10 minutes before departure and set it to feed 2 to 3 drops per minute.
3. Throughout the run always start the pump soon after the locomotive throttle is opened, and stop it just before the throttle is closed.
4. When the pump is forcing water into the boiler the Worthington cab gauge will indicate as follows:

The gauge hand will show a pressure higher than boiler pressure and will swing back and forth regularly. Each forward movement of the hand indicates *one* stroke of the pump. The gauge hand should not swing more than $\frac{1}{2}$ inch.

5. Regulate the speed of the pump so as to maintain a constant water level throughout the run. The harder the locomotive is working, the faster the pump must be run.

6. If necessary to run the pump while the locomotive is drifting, or while a light throttle is being used, run it slowly at a speed that will just supply the water that is used.

7. If the water level is to be raised, do so by speeding up the pump while the locomotive is using steam. At such time the heater delivers the hottest water.

8. When approaching a station or siding where a considerable stop is to be made, raise the water level in the boiler so that by the time the throttle is closed for the stop, there will be sufficient water to last during the stop.

9. When the locomotive is working hard the pump delivers the water so hot that the pump may race a few strokes when the reverse lever is hooked up, or the throttle partially closed. This racing can be prevented by slowing down the pump just before the change is made. After a few seconds the pump speed can be increased again without causing racing.

10. Carry the reverse lever in the same notch that it would be carried in if the injector were used. The sound of the exhaust is much softer with heater operation because the heater takes $\frac{1}{7}$ of the exhaust steam from the exhaust passage and only $\frac{6}{7}$ as much steam passes through the exhaust nozzle as with injector operation. Therefore, if the position of the reverse lever is set by sound, the lever will be dropped down farther than it should be, and too much steam will be used.

11. In cold weather during long stops, or while drifting with the pump shut off, the water in the suction pipe and hose is liable to freeze. To prevent this, crack the suction steam-heat valve only just enough to prevent freezing. Close the valve before starting the pump. Do not open this valve too wide, because too much steam will overheat the water in the suction pipe and the pump will not raise the water. In severe cold weather the pump should be run very slowly while the the locomotive is not using steam, and, if necessary, the suction heater pipe valve may be cracked also.

12. The normal pump speeds and capacities are as follows:

Pump Size No.	Normal Speed R. P. M.	10% Above Normal Speed	FEEDWATER CAPACITIES		
			Gallons Per Hour	Gallons Per Minute	Pounds Per Hour
1	78	86	2,400	40	20,000
2	70	77	3,900	65	32,500
3	65	72	5,400	90	45,000
4	54	60	7,200	120	60,000
4½	63	70	8,400	140	70,000
4½	54	60	10,000	166	83,000

If a pump cannot be made to run at its rated speed, or if in order to supply its capacity, it has to be run at a speed 10 per cent. higher than normal, the pump should be reported for attention.

CENTRIFUGAL PUMPS

28. **Types of Centrifugal Pumps.**—Centrifugal pumps are used with the Worthington type S and the Coffin feedwater heating equipments explained farther on, and as this type of pump has never before been used on locomotives, a description of the principle on which it operates becomes necessary.

Centrifugal pumps are broadly divided into two classes, namely, volute pumps and turbine pumps. The cold-water pump of the Worthington type S feedwater heating equipment is of the volute type; the cold-water pump used with the Coffin feedwater heating equipment is of the turbine type.

29. **Volute Pump.**—A sectional view of a simple type of volute pump is shown in Fig. 17. The term *volute* is derived from the shape of the passageway that surrounds the impeller or rotating member *a*, as the beginning of this passageway is narrow at *b* and increases gradually in width to the maximum at the entrance to the nozzle at *c*. The impeller is mounted on the shaft *d* and the water is delivered by gravity to the center of the impeller or the openings at *e*. With the pump operating at full capacity, the impeller, which is merely two disks with a number of curved vanes cast on their interior surfaces, is revolving at a speed of about 3,500 revolutions per minute. As the inner ends of the vanes revolve rapidly around in the water, each vane slices off a strip of water and impels or carries it to the outer ends of the vanes or to the circumference of the impeller. Here it is thrown off in a tangent direction at a high velocity into the

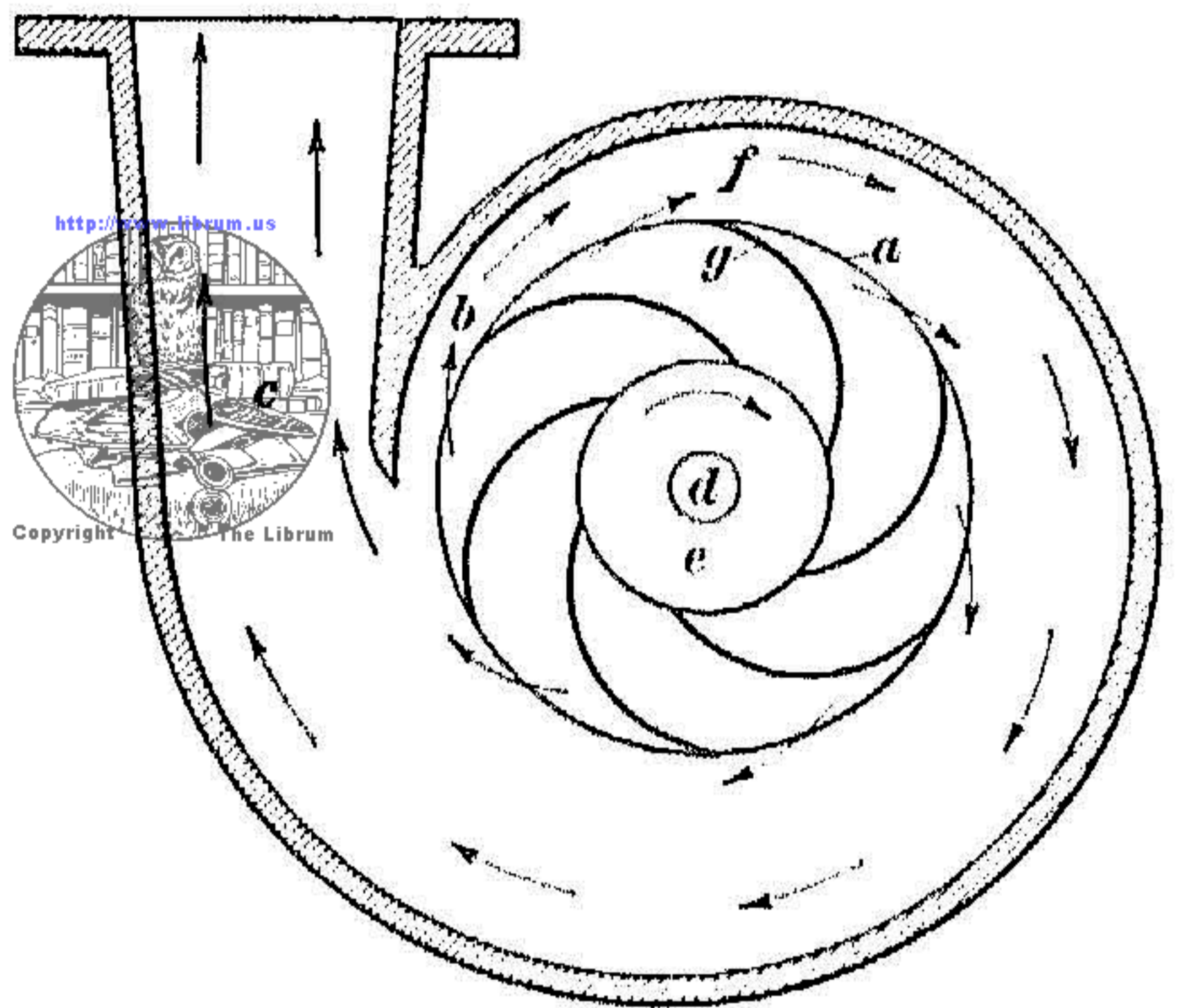

FIG. 17

volute passageway and continues around to the inlet of the nozzle, where it meets the water that has been previously discharged. The water in the discharge pipe forward of the nozzle, owing to the resistance offered by the boiler check, is moving much more slowly than in the pump, and the impact of the water at a high velocity against the more slowly moving water causes the pressure of the water in the discharge pipe to increase sufficiently to open the check-valve and enter the boiler. Hence, if it were not for the fact that the water in the discharge pipe is moving more slowly than in the pump, there would be but little increase in the pressure of the water; that is, if the end of the discharge pipe were open to the atmosphere, very little pressure would be developed in the pipe.

The slower movement of the water in the discharge pipe is brought about by the boiler check, the opening of which is resisted by the boiler pressure. The delivery pipe is always larger in area than the opening through the check-valve so that it restricts the passage of water through it. If the area of the discharge pipe is four times the area through the check-valve, then the velocity of the water in the discharge pipe will be only one-quarter of the velocity of the water by the check-valve.

30. If the water that is moving at a high velocity in the pump were permitted to discharge directly against the more slowly moving water in the discharge pipe, the result would be violent swirls and eddies in the water that would reduce the efficiency of the pump. Such an action can be prevented by changing from velocity to pressure gradually, and this is accomplished by widening the neck of the pump to form a nozzle. Such a construction lessens the velocity of the water and so brings about a gradual equalization of velocities between the fast-moving water in the pump and the slower-moving water in the discharge pipe. The transition from velocity to pressure will then occur less abruptly than if the nozzle were straight. There is therefore a gradual decrease of velocity in the nozzle which is accompanied by a gradual increase in pressure, the same as occurs in the delivery tube of an injector, until the pressure finally becomes high enough to open the boiler check.

The reason for the gradual enlargement of the volute passage is to accommodate the increase in the volume of water delivered by the vanes, and so keep the velocity of the water constant. For example, the space at *f* must be large enough not only to accommodate the water thrown off by the vane *g* but also large enough to permit the water that has already accumulated in the passage up to this point to escape. Thus, the water is maintained at a constant velocity in the volute case. The curve of the vanes on the impeller conform to the path a particle of water would follow if it were dropped on a rapidly revolving flat disk, so that the vanes cause the water to be thrown off with the least restriction to movement.

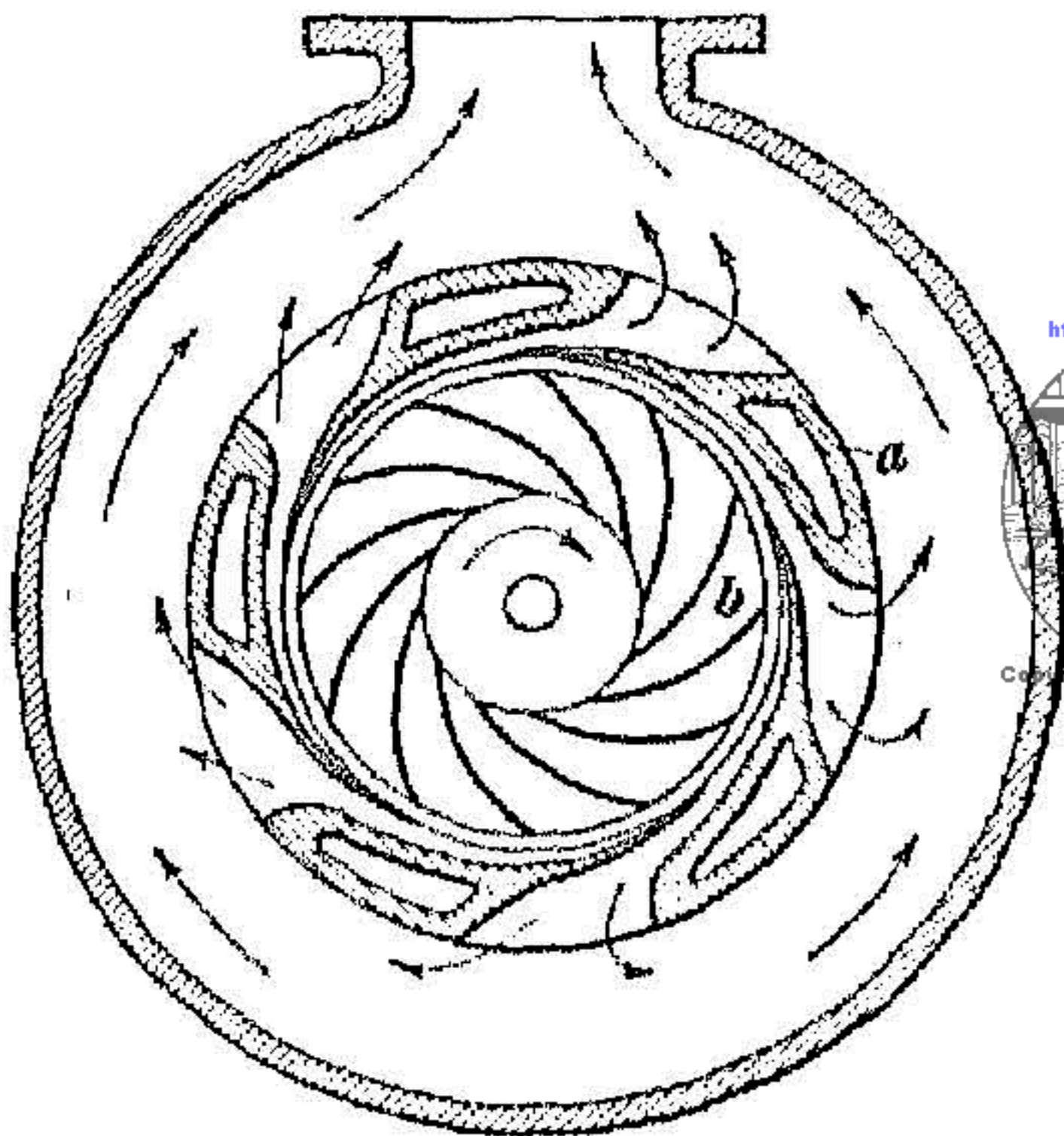

FIG. 18

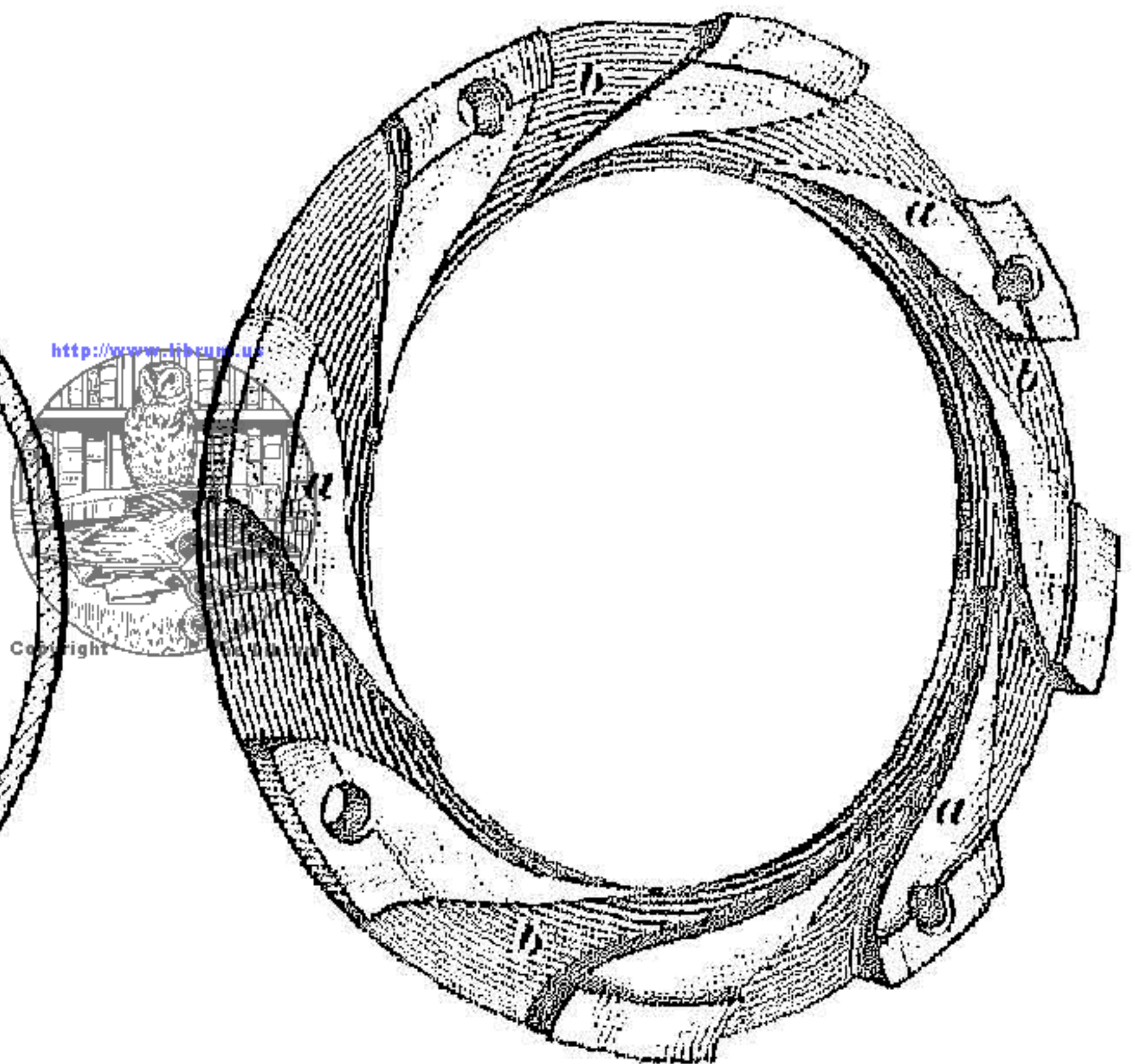

FIG. 19

31. **Turbine Pump.**—The difference between a volute pump and a turbine pump, shown diagrammatically in Fig. 18, is that the latter type of pump has a diffusion ring *a*. Such a ring is shown in detail in Fig. 19, in which the parts *a* are the diffusing vanes that form the expanding passages *b*. This ring does away with the necessity for having a volute passageway or case, although such a case may be used if desired. The impeller *b*, Fig. 18, serves the same purpose as with the volute pump, but the diffusion ring changes the velocity of the water into pressure at an earlier stage; that is, the water after being thrown off from the impeller passes through the passageways in the diffusion ring, each of which serves the same function as the nozzle of a volute

pump. These passages widen toward the outlet and so reduce the velocity of the water gradually, thereby converting velocity into pressure. Hence, the case of this type of pump is under pressure in contrast with the case of the volute pump, which is subjected to water at a high velocity but at a low pressure. The pressure developed by a centrifugal pump depends on the velocity at which the water leaves the periphery of the impeller, and this velocity depends on the diameter of the impeller and its speed of rotation. The Worthington pump is adjusted for a speed of 3,600 revolutions per minute and the Coffin pump is set to trip at a speed of about 9,500 revolutions per minute.

WORTHINGTON TYPE S LOCOMOTIVE FEEDWATER HEATING EQUIPMENT

ARRANGEMENT AND OPERATION

32. **General Description.**—The Worthington type S locomotive feedwater heating equipment, Fig. 20, consists of three distinct elements; the cold-water pump, the hot-water pump, and the heater. These parts can be located on the locomotive to secure the best arrangement compatible with the available space, the distribution of the weight, convenience of operation and maintenance, and the general appearance of the locomotive.

Cold water from the tender is supplied to the heater by a constant speed, low discharge pressure, turbo-centrifugal pump, operated by a Pyle-National steam turbine and is located directly in front of the tender hose. The heater, into which exhaust steam from the locomotive cylinders is vented through a pipe, is located on or in the smokebox either in front of or back of the stack, and is equipped with a spray valve and a heating chamber. The water level in the heater is regulated by a float valve located in the cold-water inlet, hence the cold-water pump will deliver as much or as little water to the heater as is permitted by the opening of the control valve.

The hot-water pump as well as the cold-water pump is driven by steam from the locomotive turret, the operating handle of the throttle valve being conveniently located near the engineer or fireman. The exhaust steam from the hot-water pump is piped into the heater, where it assists in heating the feedwater.



- 1—Turret Valve
- 2—Operating Valve
- 3—Suction Heating Valve
- 4—Cab Gauge

- 5—Cold Pump Steam Pipe
- 6—Hot Pump Steam Pipe
- 7—Heater Pipe
- 8—Squirt Hose Pipe

- 9—Lubricator Pipe
- 10—Turbine Exhaust Pipe
- 11—Cold-Water Discharge Pipe
- 12—Cold-Water Suction Pipe

- 13—Cold-Water Pump
- 14—Hot-Water Pump
- 15—Hot Pump Discharge Pipe
- 16—Steam Strainer Clean-out Valve

- 17—Cab Gauge Pipe
- 18—Hot-Water Suction Pipe
- 19—Drifting Control Valve
- 20—Hot Pump Exhaust Pipe

- 21—Safety Valve
- 22—Locomotive Exhaust Pipe to Heater
- 23—Heater
- 24—Heater Air Vent Pipe

33. The heater is provided with a drifting control valve that automatically limits the hot-water pump to a predetermined low speed, thus making it impossible for the operator to run the pump at high speed when the locomotive throttle is closed and when there is no exhaust steam available from the locomotive to heat the feedwater. This valve is placed in the exhaust pipe of the hot-water pump and is operated by the pressure in the steam pipe or steam chest of the locomotive. When the locomotive throttle valve is closed or nearly so, the drifting valve

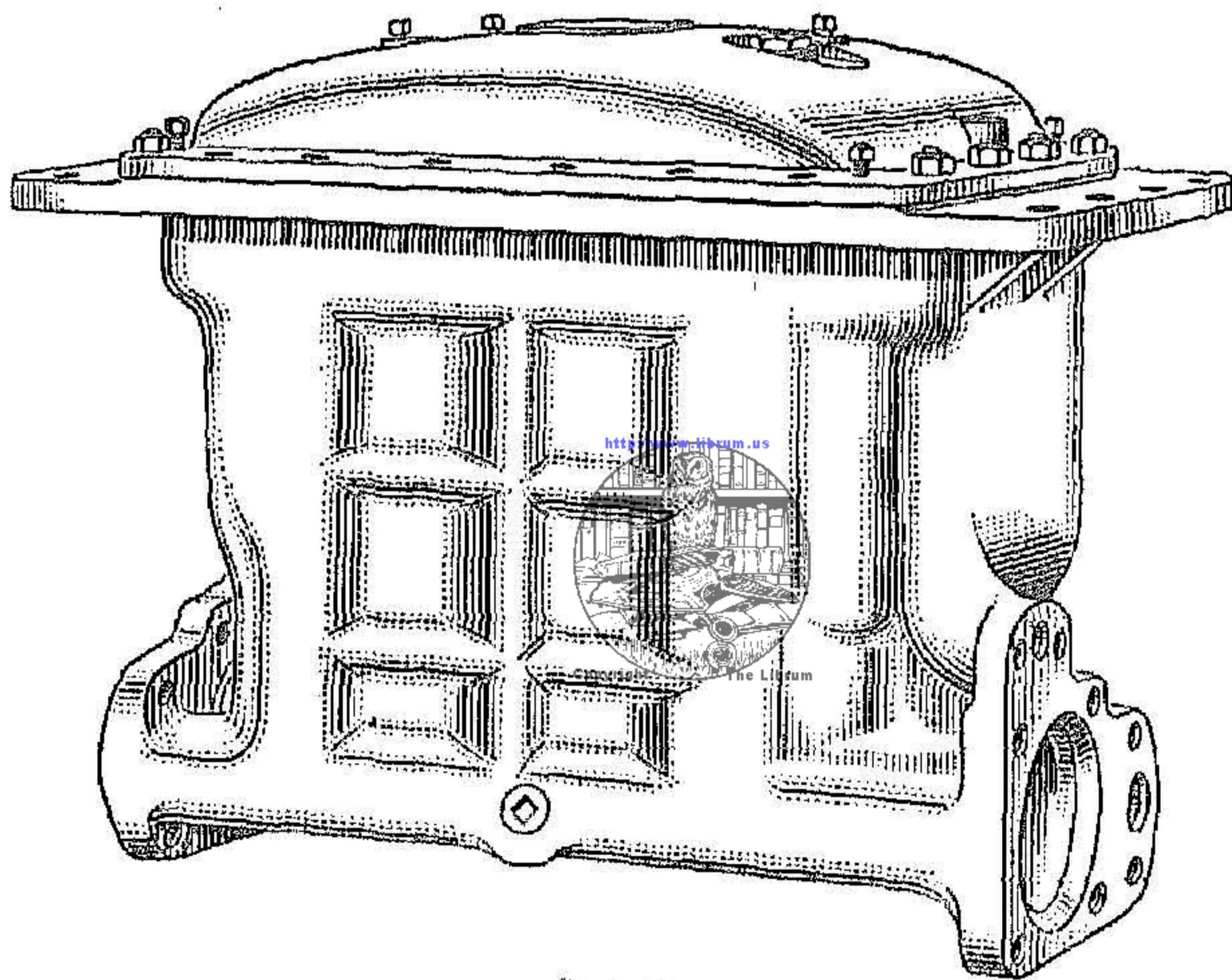

FIG. 21

automatically closes, and slows down the speed of the pump, thus reducing the amount of water delivered to the boiler. As soon as the throttle is again opened, the drifting control valve also opens and allows the hot-water pump to resume its normal speed.

The cold-water pump delivers water through the pipe 11, Fig. 20, to the heater, which is supplied with exhaust steam from the cylinders through the pipe 22. The hot water is drawn from the heater by the hot-water pump through the pipe 18 and is delivered to the boiler through the pipe 15. The steam pipe for the cold-water pump is indicated by 5 and the steam pipe for the hot-water pump by 6; the flow of steam through both of these pipes is controlled by the operating valve 2. The suction heater

valve is indicated by 3 and the squirt hose connection by 8. The hot-water pressure gauge is shown at 4.

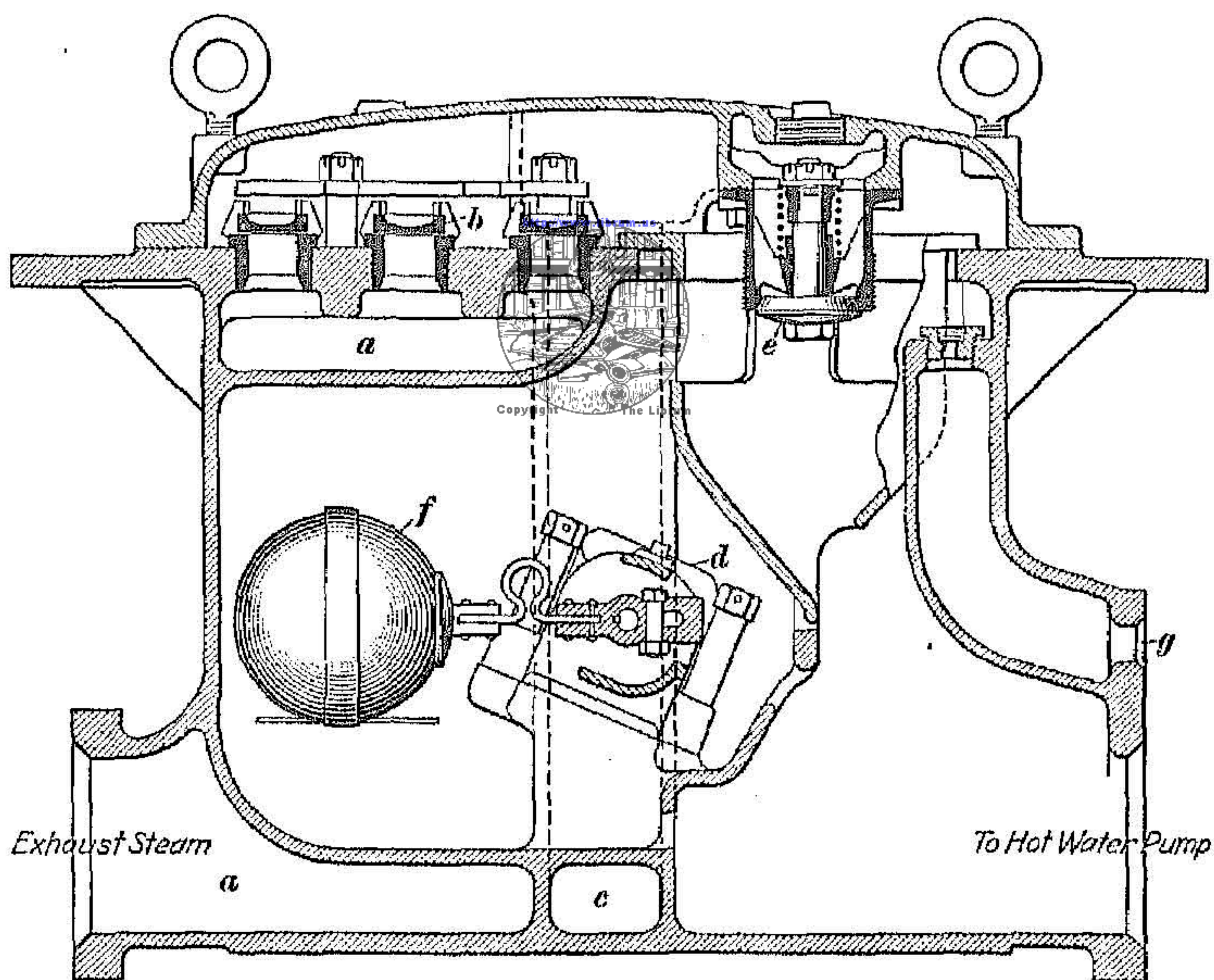
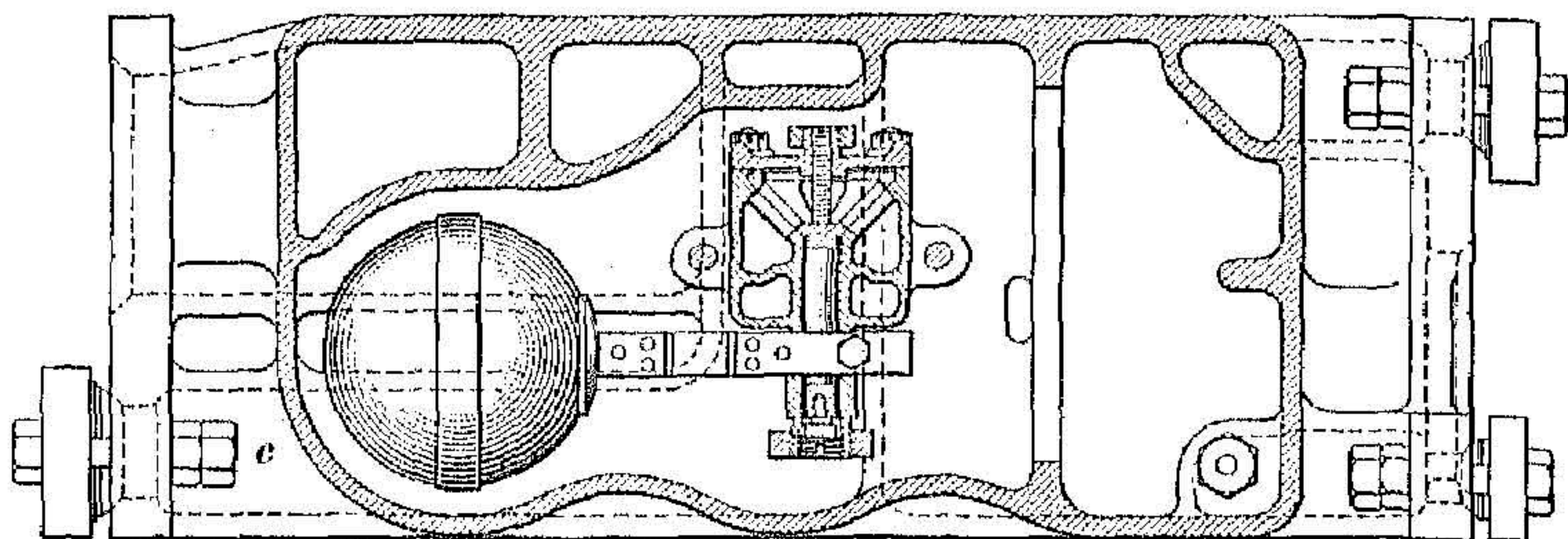

FIG. 22

34. **Heater.**—An exterior view of the heater is shown in Fig. 21 and a sectional view in Fig. 22. The exhaust steam enters the heater at the point shown, passes up and around the water compartment to chamber *a*, unseats the exhaust check-valves *b*, and enters the water compartment of the heater. The cold water from the cold-water pump enters the heater at *c* and

passes first through the water-control valve *d*, thence to the spray valve *e*, which is forced open against the tension of its spring. The water passes through this valve in the form of a spray, which, through mixing with the exhaust steam, becomes heated and falls to the bottom of the heater. The hot water is drawn from the heater at the outlet shown by means of the hot-water pump. The water level in the heater is maintained at a pre-determined level by the water-control valve. When the water level rises to a certain point, the float *f* lifts and closes the valve *d*

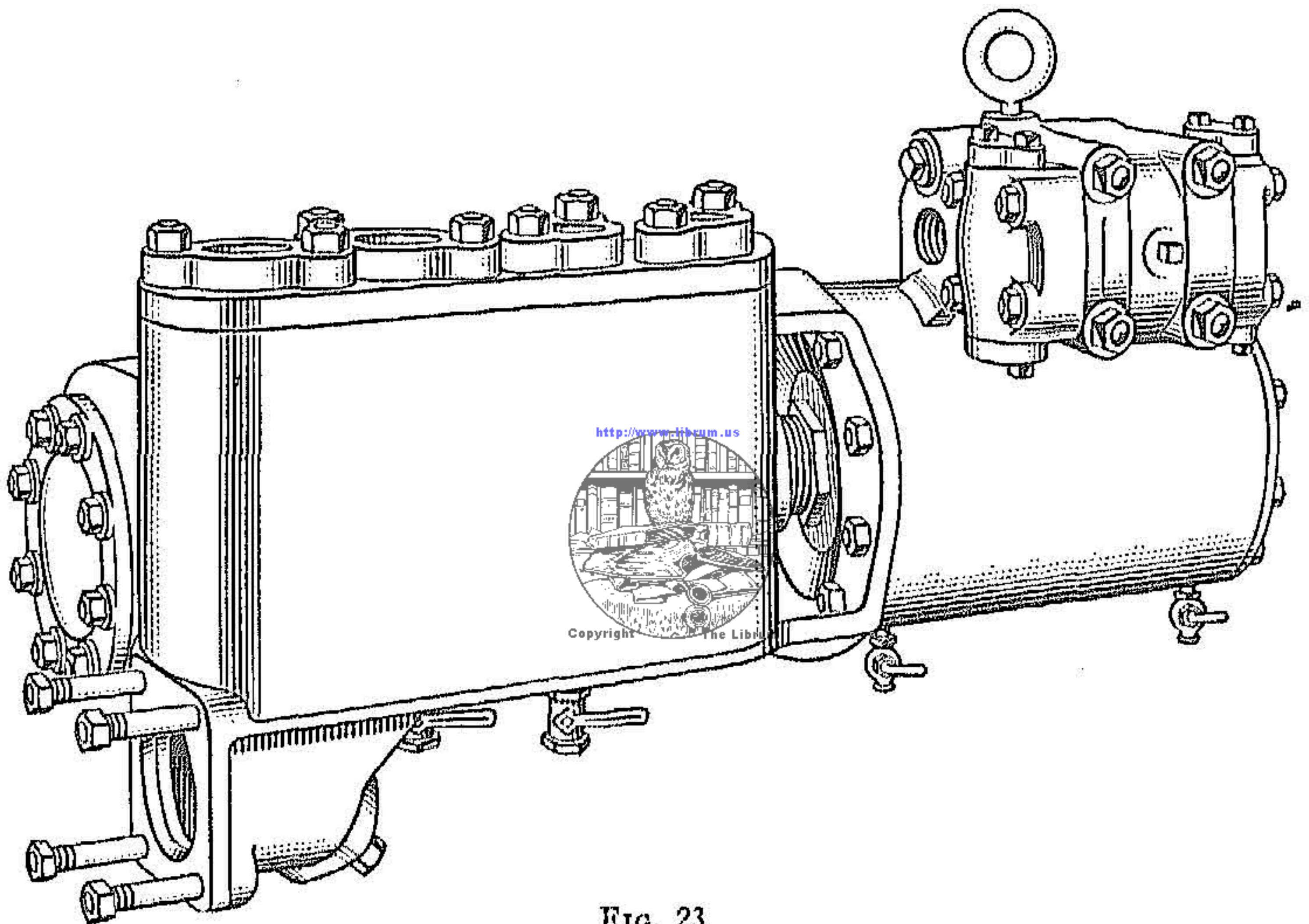

FIG. 23

in the cold-water supply passage; when the water level lowers, the valve opens. With the valve closed, the cold-water pump is still in operation but it does not build the pressure up above 60 pounds. When this pressure is reached the impeller merely keeps churning the water.

The air that separates from the water when it is heated escapes through a choke to the air-vent connection *g*, which is piped to a convenient position near the track. The oxygen of the air if permitted to enter the boiler would cause pitting and corrosion.

The exhaust check-valves, which with this equipment are placed in the heater, prevent the exhaust steam from the hot-water pump from escaping from the heater when drifting.

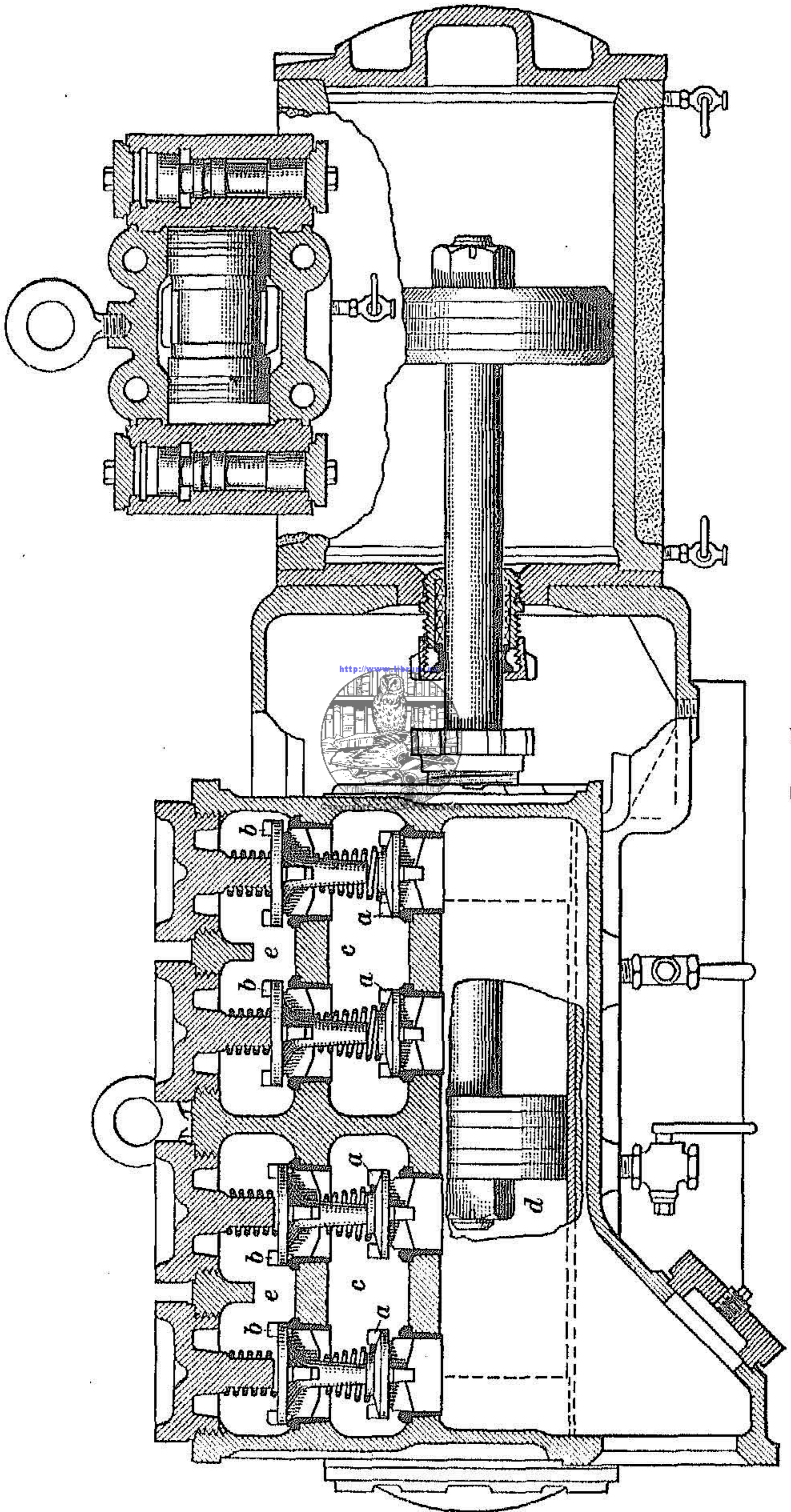

FIG. 24

35. **Hot-Water Pump.**—An exterior view of the hot-water pump is shown in Fig. 23, and in Fig. 24 is shown a sectional view. The steam end of the hot-water pump is similar to the steam end of the BL heater and requires no description. The water end of the pump has two inlet valves *a* and two discharge valves *b* for each end of the cylinder, separated it will be noted by a vertical partition. With the water piston moving to the right a partial vacuum forms behind it in the water passage that connects to chamber *c*, which may be considered as a part of the cylinder, so that the water is drawn in through the inlet valves and fills the space *d* behind the piston. On the

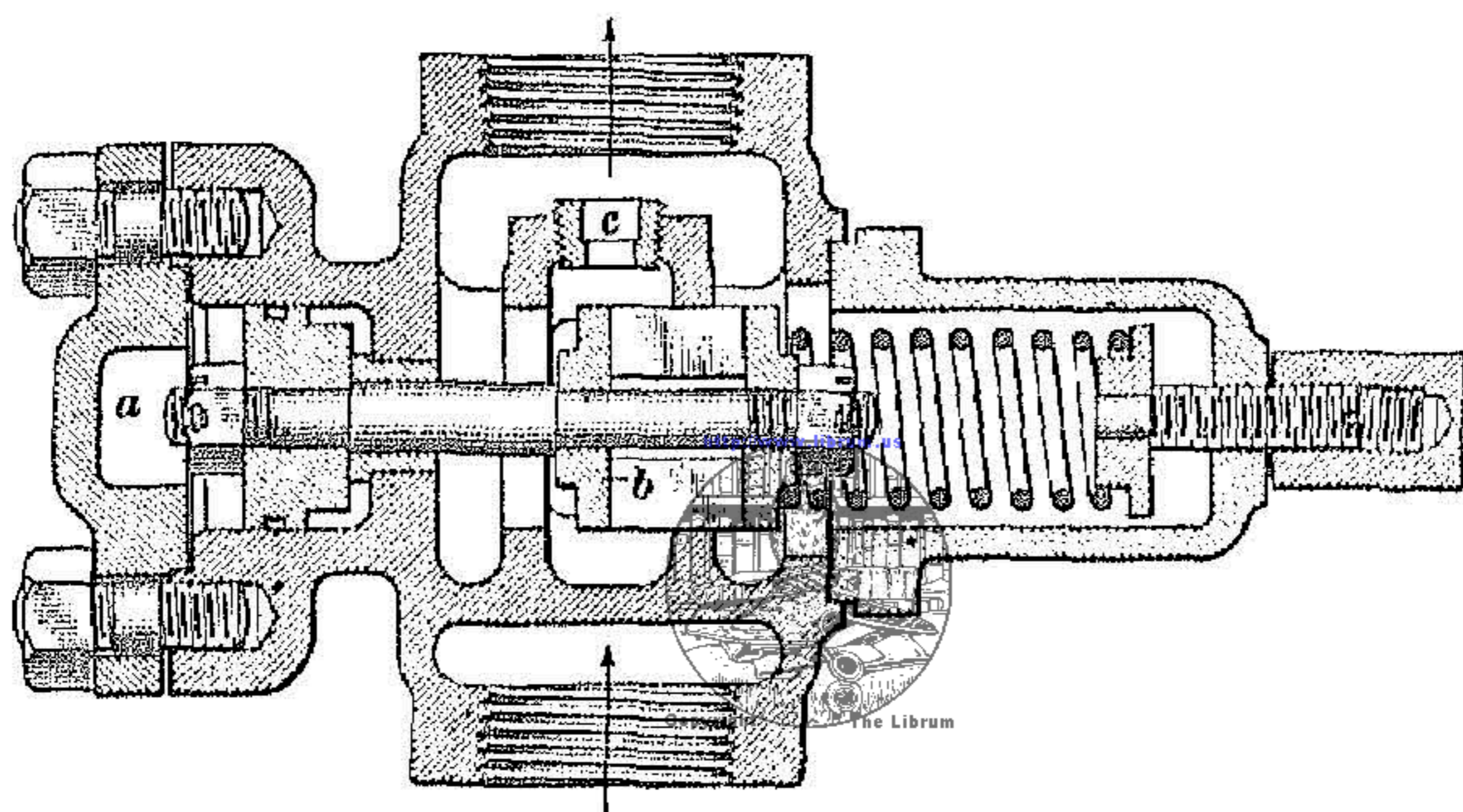

FIG. 25

return stroke the inlet valves close, the piston then forces the water back into chamber *c*, the discharge valves then rise, and the water passes to chamber *e*, which communicates with the discharge pipe.

The pump is double-acting, so when the piston is forcing the water out at one end, the water is being drawn in at the other end.

It will be noted that the discharge valves of a water pump, unlike those of an air compressor, do not have to be placed close to the end of the cylinder. The reason is that water cannot be compressed, whereas air can be compressed and hence has to be completely expelled at each stroke, otherwise fresh air will not enter. A safety valve is provided in the exhaust pipe of the hot-water pump between the drifting control valve and the heater to relieve any pressure in it. This valve is set at 100 pounds.

36. Drifting Control Valve.—The drifting control valve, Fig. 25, is placed in the exhaust pipe of the hot-water pump. Its purpose is to prevent the pump from being run fast while the engine is standing or drifting. It is automatic in operation; the pump will automatically slow down when the locomotive throttle is closed and will speed up again when the throttle is opened. The valve is controlled by live steam pressure from one of the steam pipes of the locomotive, led to chamber *a* by a $\frac{3}{8}$ -inch pipe.

When the pressure in this pipe and in chamber *a* exceeds 50 pounds, the valve *b* opens, as shown, against the resistance of

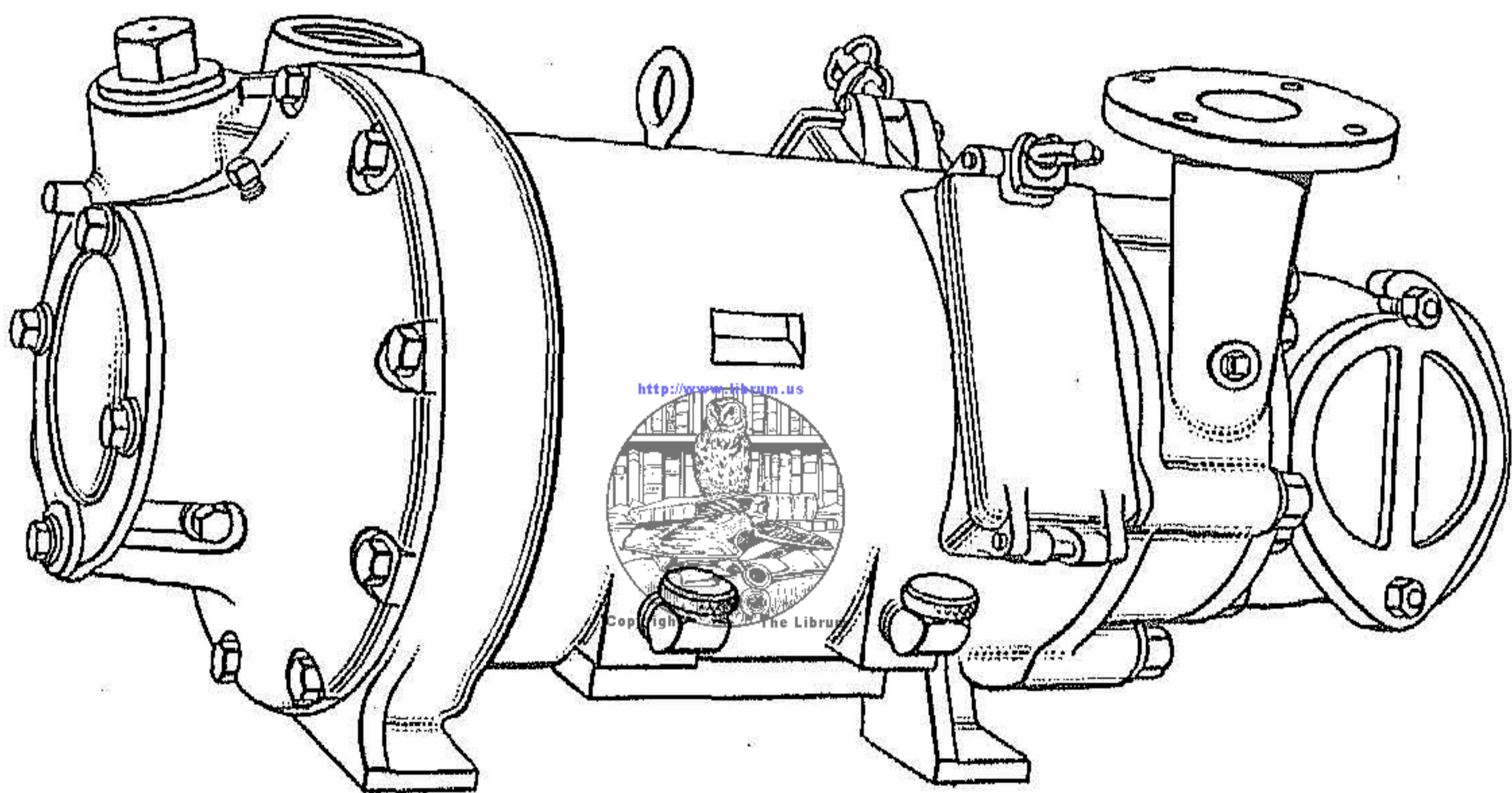
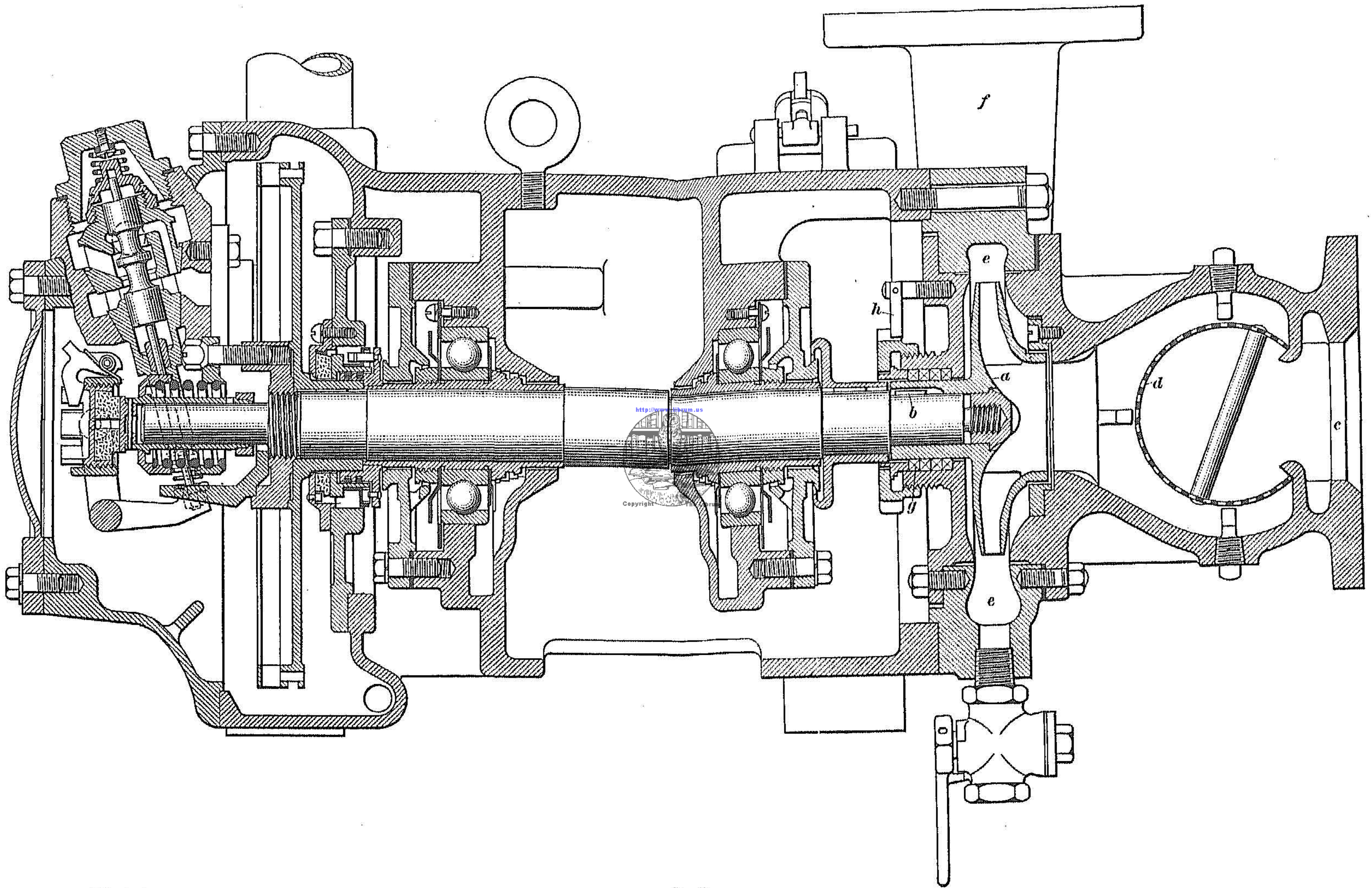

FIG. 26

the spring; exhaust steam from the pump which is present in the interior of the valve then passes through it to the heater as shown by the arrows. When the pressure in chamber *a* is reduced to less than 50 pounds, the valve *b* closes, compelling the pump exhaust to pass to the heater through the small orifice in the plug *c*. This restriction of the exhaust from the pump slows up its speed, and prevents the feeding of the boiler at times when there is little or no exhaust steam passing to the heater to heat the feedwater.

WORTHINGTON TYPE S COLD-WATER PUMP

37. General Description.—A perspective view of the Worthington type S, cold-water pump is shown in Fig. 26 and a sectional view in Fig. 27. The water portion is on the right



BB 508D 2517

FIG. 27

and the steam turbine that drives the impeller in the water end is on the left. As the operation of a centrifugal pump has already been described, it will be only necessary to consider the details of construction. The pump is of the volute type and the impeller *a* is keyed to the shaft by the key *b* and is held on by the nut shown. Water enters through the suction inlet *c* and passes through the strainer *d* into the opening in the impeller. From the impeller the water is discharged into the volute passage *e* through which the water passes to the cold-water outlet *f*. This

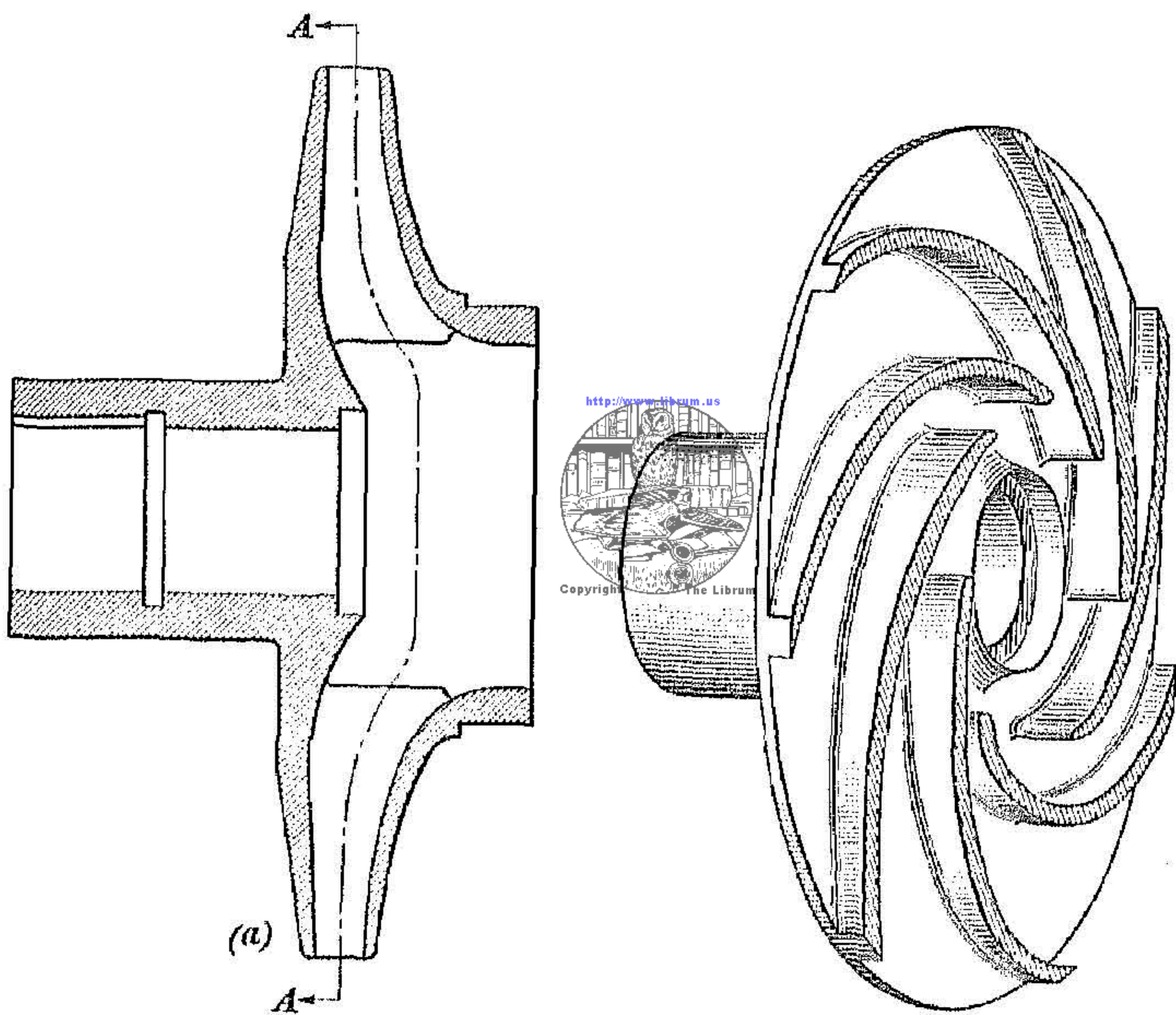

FIG. 28

passageway is drained by the drain cock shown. The passage of water along the shaft is prevented by the packing *g* held in the stuffingbox by a gland and a packing nut that is prevented from coming loose by the locking device *h*. The water end of the shaft as well as the steam end is carried on ball bearings that run in oil. Each bearing has the usual arrangement for adjustment, and also oil flingers for eliminating the loss of oil.

In Fig. 28 (*a*) is shown a section through the impeller; in view (*b*) is shown a perspective view of the interior of the

impeller, the section being taken through the line *A-A*, view (a), so as to show the contour of the water vanes.

38. Operation of Steam Turbine.—The passage of the steam through the steam turbine is shown in Fig. 29. In view (a) is shown a section of the turbine end at right angles to the shaft and in (b) is shown a section through the nozzle.

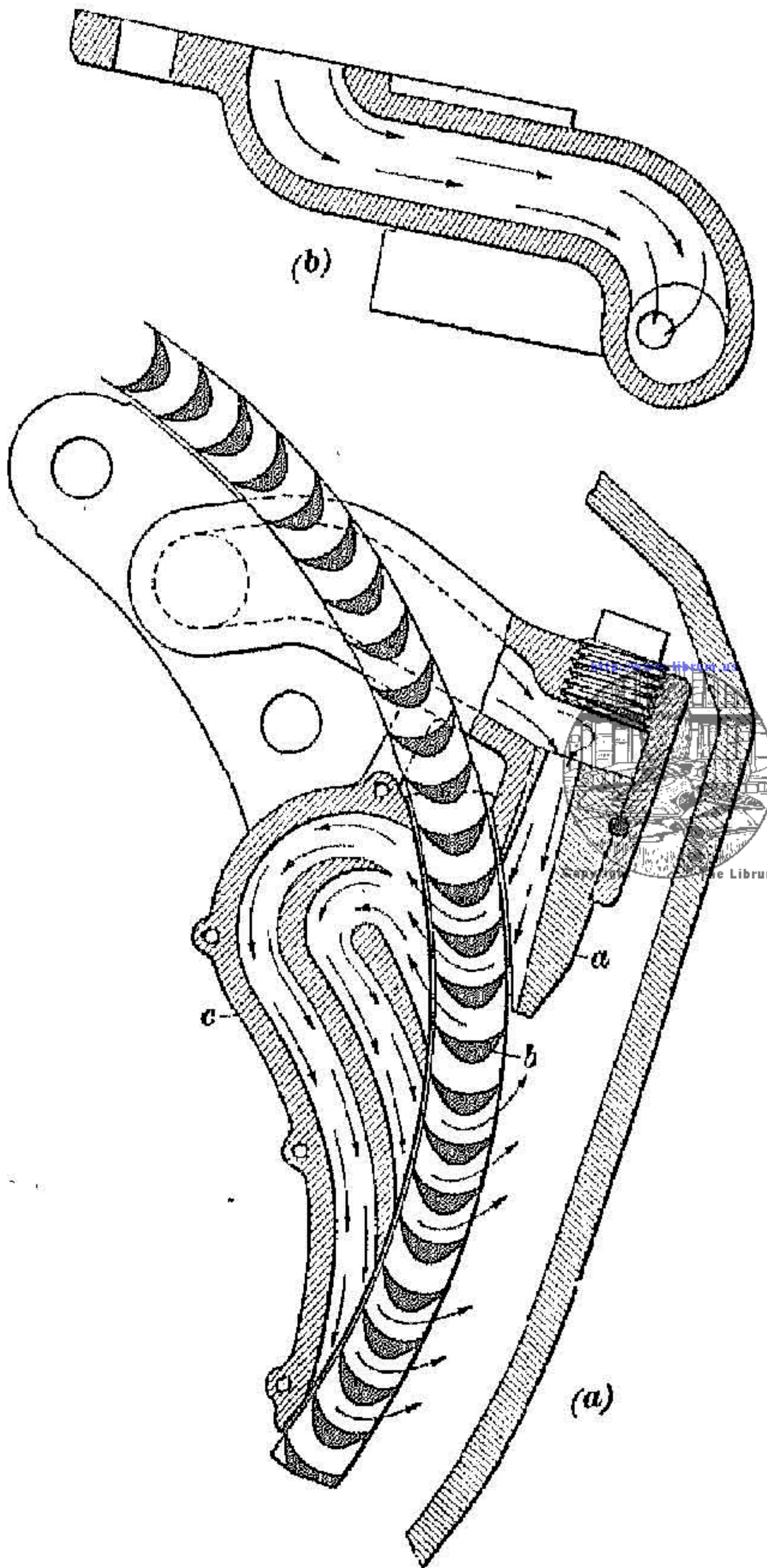

FIG. 29

As with the steam nozzle of an injector, the nozzle *a* converts heat or the random and aimless movement of the steam particles into work, or into a definite movement of the particles into a forward direction at a high velocity. A pressure is developed against the buckets *b* by the impact of the stream of particles, which causes the turbine wheel to turn in the direction of the arrow. After striking the buckets, the steam rebounds in the opposite direction as shown. The efficiency of the turbine can be increased by using the steam over again, so that the steam is brought back into the proper direction relative to the bucket

wheel by directing it through the return-guide passage *c*. This passage reverses the direction of the flow of steam and brings it again in contact with the buckets. By this time most of the energy of the steam has been expended and it is now permitted to pass out to the exhaust.

39. **Governor.**—The speed of the bucket wheel, and hence the speed of the pump, is governed by the amount of steam that discharges through the steam nozzle, and this is regulated by the

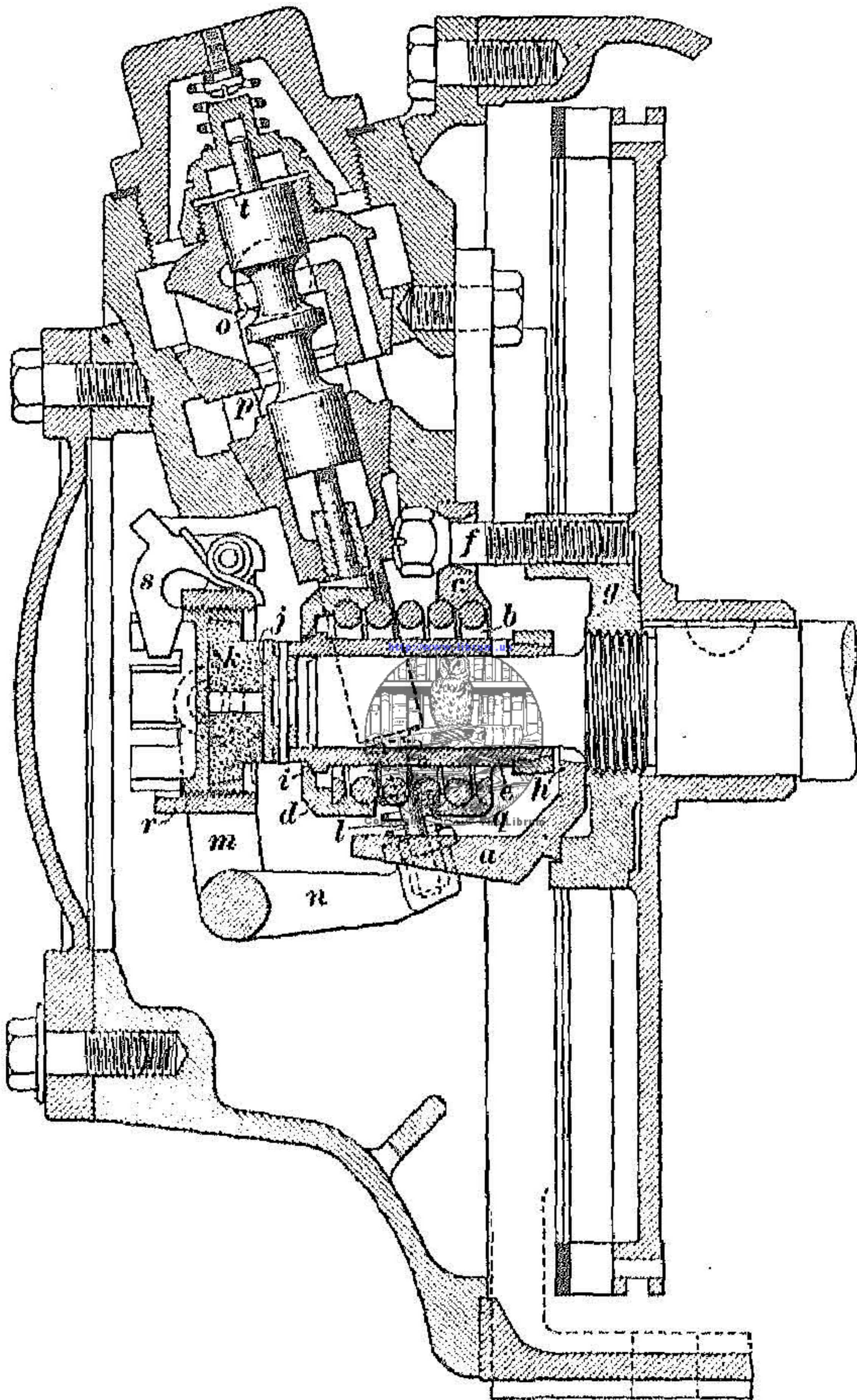

FIG. 30

governor. The governor assembly, complete, is shown in Fig. 30, and the governor proper is shown in Fig. 31. It is composed of two governor weights *a*, a governor spring *b*, a governor yoke *c*, a spring retainer *d*, a governor sleeve *e*, and two governor adjusting screws *f*, mounted as one unit on a governor

stand *g*, which also acts as a nut to hold the bucket wheel in place. With the shaft, and hence with the governor, revolving, the weights move out owing to the action of centrifugal force and the heel *h*, Fig. 30, of the weights makes contact with the governor sleeve *e*, which is free to move outwards on the shaft. The movement of the sleeve is resisted when the shoulder *i* comes in contact with the governor spring retainer, which encloses and holds the end of the governor spring. As the inner end of the spring is secured by means of a yoke and the governor

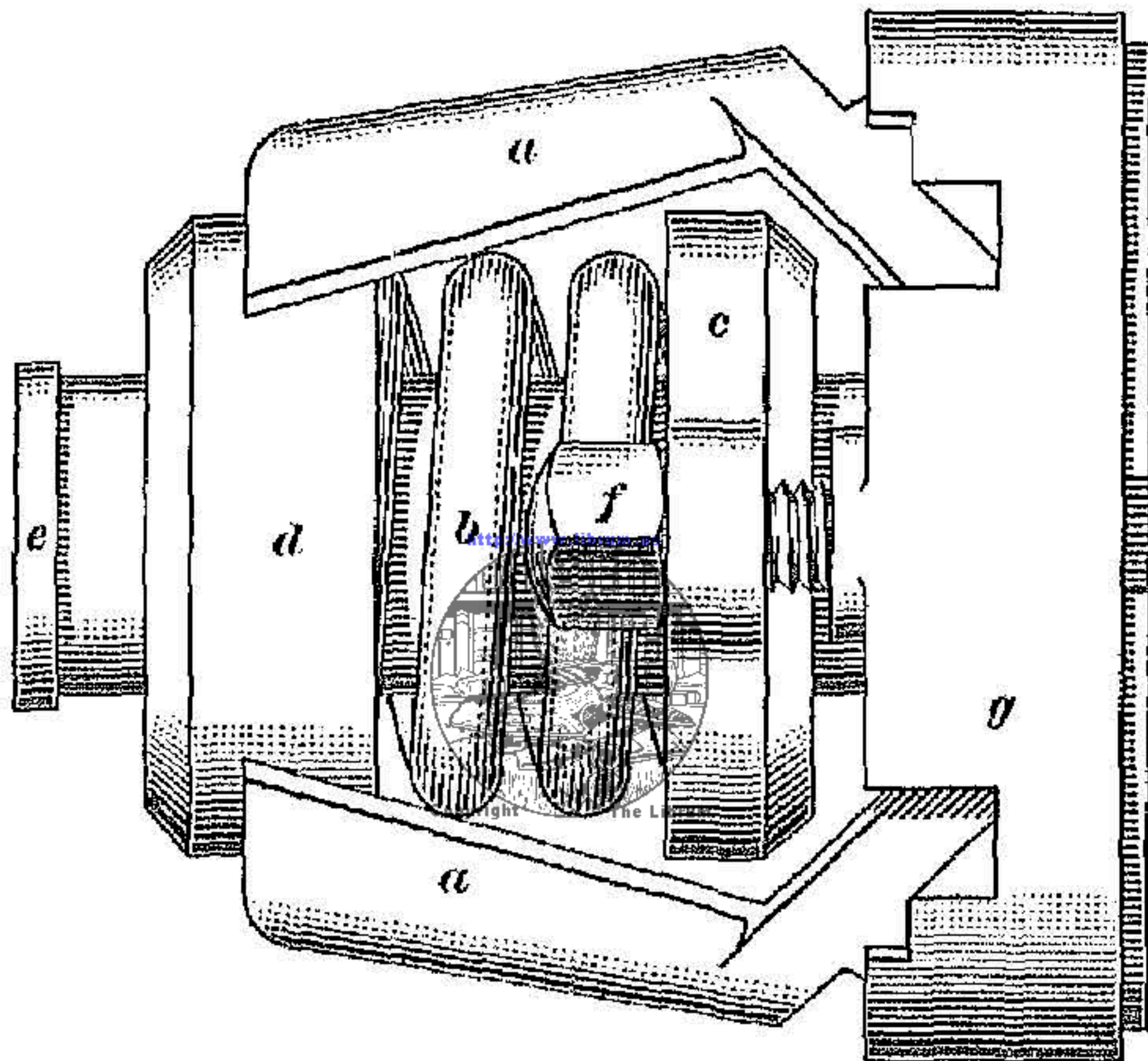

FIG. 31

screws to the governor stand, the outward movement of the governor sleeve is then resisted by the tension of the governor spring, that is, the spring is under tension and not compression. If the speed of the shaft is so great that the tension of the spring is overcome, the end *j* of the sleeve will make contact with the thrust block *k*, which is mounted exterior to the shaft near its end. The outward movement of the thrust block is converted into a lifting movement at the valve stem *l* by the bell-crank or governor arm *m*, which is forked so as to yoke around the thrust block *k* and is supported at the ends by two retaining screws inserted one on each side of the turbine casing. This arrangement will be evident from Fig. 32, in which (*a*) is a horizontal section taken through the casing and shows the parts that trans-

fer the movement from the governor sleeve to the valve, while (b) is a vertical section that shows the same parts as viewed from the end. When the arm *m* moves outwards, the other arm *n* of the bell-crank pushes upwards on the valve stem and throttles

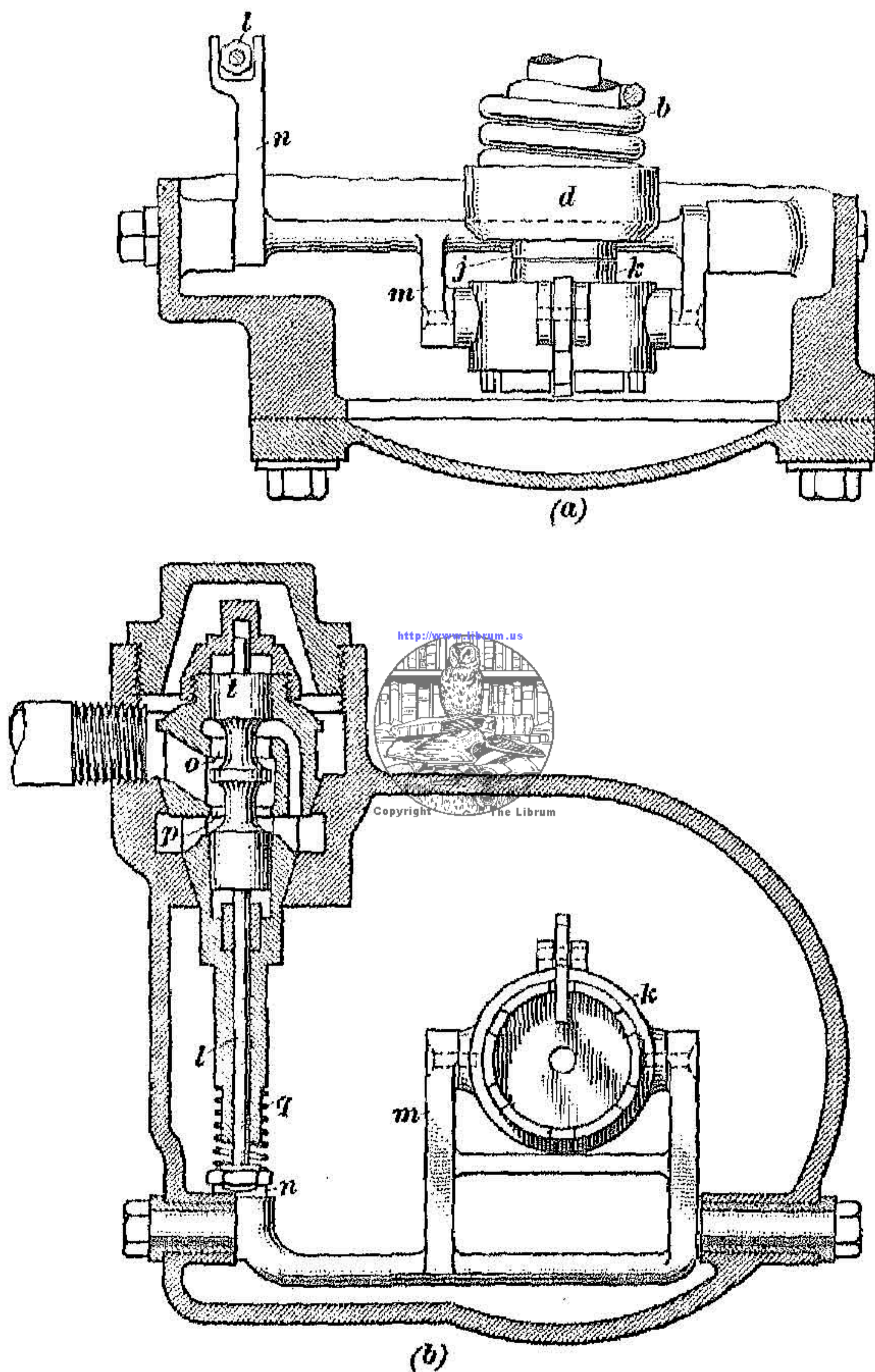

FIG. 32

the steam at the points *o* and *p*, thus decreasing the supply of steam passing through the nozzle.

As the speed reduces, the governor weights, owing to the reduced centrifugal force, move in again, and the governor spring which has been under tension, moves the sleeve inwards

and releases the pressure from the thrust block. The valve spring q then returns the valve to normal or open position and widens the port opening. The governor operates when the speed exceeds 3,600 revolutions per minute.

40. **Adjustment.**—The governor is adjusted properly at the factory and no readjustment should be made unless, when checked with a speed indicator, the speed is found to be too high or too low. The adjustment is made at two points. To begin with, the proper tension must be placed on the governor spring, which is done by adjusting the two governor adjusting screws f , Figs. 30 and 31, tightening them up the same amount for increased speed, and loosening them the same amount for decreased speed. Tightening one more than the other will result in binding the governor parts. Adjustment for the wear of the parts is made by turning the thrust block k farther into the holder or outside ring r , thereby decreasing the clearance between the block and the governor sleeve.

Turning the thrust block k into the outside ring or to the right raises the valve stem and decreases the speed; turning it to the left has the reverse effect. The adjustment is correct when the top of the governor valve t is flush with the top of the cage, as shown in Figs. 30 and 32 (*b*). The thrust block is locked by the locking pawl s , which falls into slots in the block.

OPERATING INSTRUCTIONS

41. The height of water in the boiler is regulated by the cab valve, which controls the speed of the hot-water pump and the cold-water pump. This operating valve and the lubricator for the hot-water pump are the only parts requiring attention while the heater is in operation.

When a hydrostatic lubricator is used for the hot-water pump, it is best to open the lubricator feed before leaving time, to be sure that the pump will be receiving oil when it is to be started. When in operation, the lubricator should be set to feed two drops of oil per minute.

To start the equipment, the operating valve should be opened slowly to force any accumulated water from the turbine steam

pipe and hot-water pump steam pipe. Then the operating valve should be regulated for the required hot-water pump speed.

The equipment should be run continuously while the locomotive is using steam, and the hot-water pump operated at the speed necessary to maintain the desired water level in the boiler.

In making short station stops it is not necessary to stop the pumps, as the drifting control valve will automatically take care of pump speeds.

For use in cold climates a small live-steam pipe, known as the suction heating pipe, with a $\frac{1}{8}$ -inch choke is provided. This pipe leads from the cab turret to the suction pipe of the cold-water pump, just in front of the tender hose. When there is danger of the suction pipe or tender hose freezing, the valve in the suction heating pipe should be open enough to prevent freezing during the time the pumps are not in operation. In the event that the suction water is overheated, the operating valve should be closed and the drain cock opened on the cold-water pump, allowing cold water to flow into the suction pipe from the tank. The drain cock should then be closed and the system is again ready for operation.



42. With feedwater heating equipment it is not necessary to fill the boiler while the locomotive is standing, in order to be ready for a start. The smaller steam requirement of the boiler feed pump, as compared with the injector and the heat returned to the boiler by the heater, makes it practicable to start the pump when the locomotive is started, without losing steam pressure. This method of operation gives the best results both from the heater and the locomotive.

If the pump has to be run at a speed that seems excessive for the work it is doing, it indicates worn piston packing, leaky valves, or choked tank valve, tank strainer or suction strainer.

If the cab-gauge hand continues to show pressure after the hot-water pump has been stopped, it does not necessarily indicate that the boiler check-valve is leaky or stuck open, as the pressure will be held up if the pump discharge valves are tight. The condition of the boiler check-valve may be tested as follows: Completely drain the heater by opening the drain cock in back

of the suction nozzle of the hot-water pump. Then open the drain cock in front of the discharge nozzle of the hot-water pump, to drain the branch pipe between the pump and boiler check. After this is drained, if steam or water continues to escape from this open drain cock, it indicates that the boiler check is leaking or stuck open.

The sound of the exhaust from the locomotive is softer when using the heater. Allowance should be made for this in judging the amount of work the locomotive is doing and in determining the position of the reverse lever.

WORTHINGTON TYPE-SA FEEDWATER HEATING EQUIPMENT

43. **General Arrangement.**—The general arrangement of the type-SA locomotive feedwater heating equipment is shown in Fig. 33. As with the type S, the type-SA equipment consists of three distinct units, namely, the cold-water pump, the heater, and the hot-water pump. Cold water from the tender is supplied to the heater by a low-pressure centrifugal pump, driven by a variable-speed turbine. It will be noted that the steam from the operating valve passes to the drifting control valve and thence by way of the control valve to the cold-water pump. The reason for this is to cause the control valve, which is float-operated, to regulate the speed and the capacity of the cold-water pump in accordance with the water level in the heater. Thus, when the water level in the heater rises, the float rises also and pulls the control valve down, thereby throttling the steam supply to the turbine. A reverse effect occurs when the water level lowers. The drifting control valve with this equipment is attached to the steam chest of the hot-water pump. This valve, as with the type S equipment, automatically reduces the quantity of steam for operating both of the pumps when the locomotive throttle is closed or in a drifting position, thus limiting the amount of water fed to the boiler when there is little exhaust steam available from the locomotive to heat the feedwater. Steam passes freely to both of the pumps when the drifting control valve is open; when it is closed the steam passes to the pumps through a small orifice in the valve body.

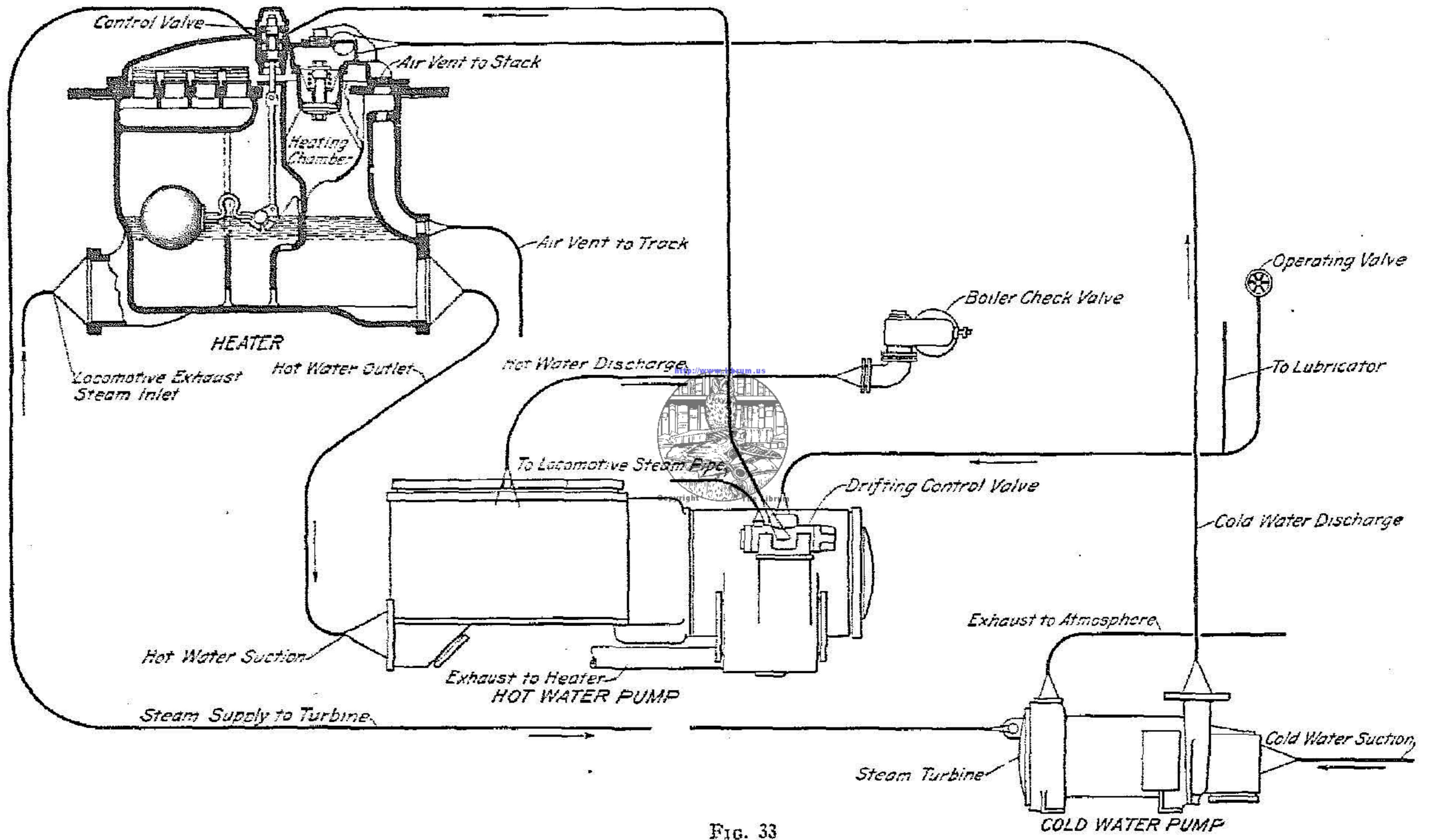

FIG. 33

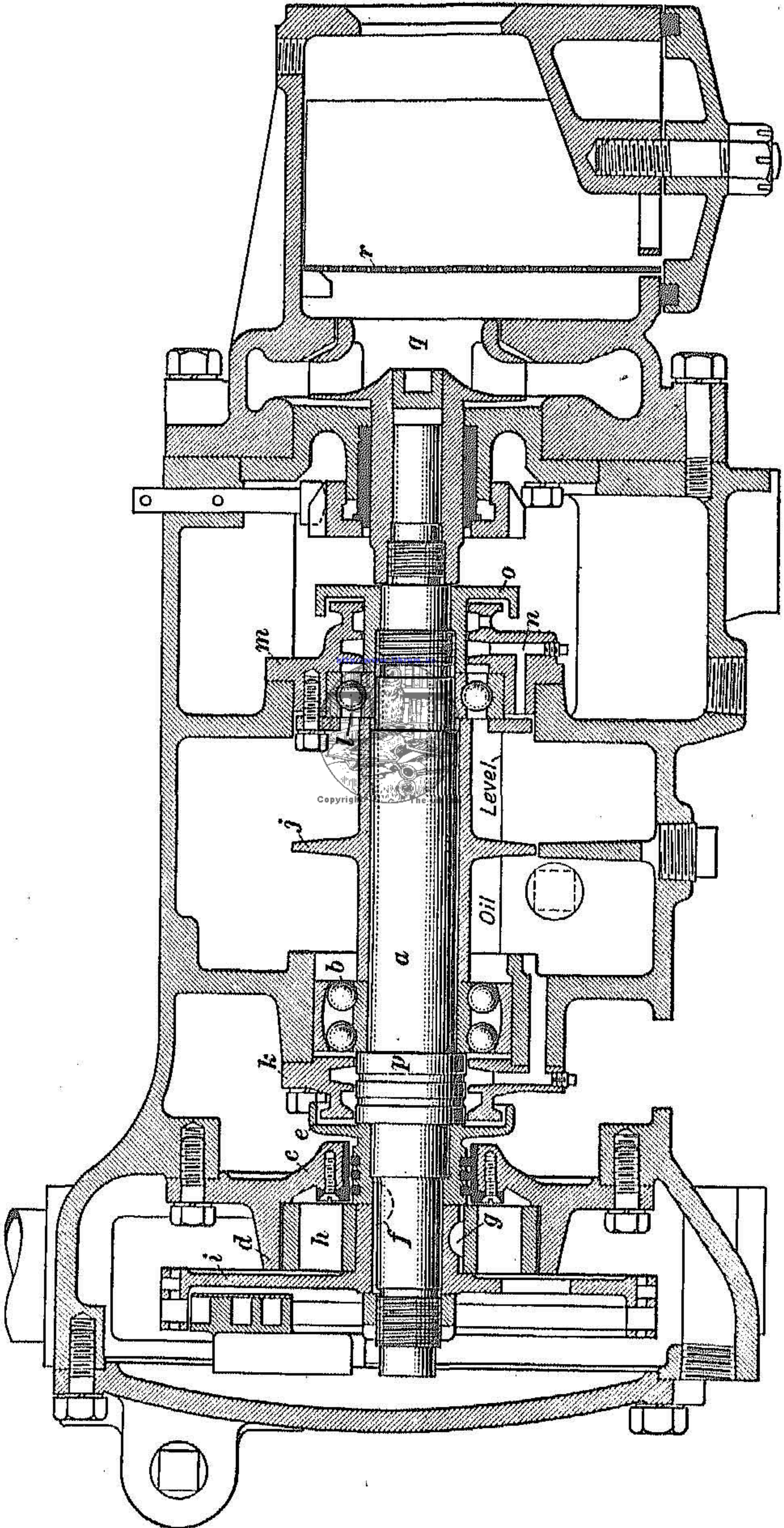

FIG. 34

44. **Cold-Water Pump.**—The cold-water pump, Fig. 34, of the SA equipment differs mainly from the one used with the type S in that the governor with its valve is not used; instead, a simple form of brake arrangement is employed to limit the speed of the pump. As already explained, the amount of steam admitted to the pump is governed by the control valve, the position of which is dependent on the water level in the heater. The turbine end of the pump is virtually the same as the type S and requires no description. A comparison of Figs. 27 and 34 will serve to disclose the difference between the two types of pumps. In the SA pump (Fig. 34), the shaft *a* is carried on ball bearings *b* that differ somewhat in arrangement from those of the other pump. The turbine packing housing *c* with which is incorporated the brake drum *d* is bolted to the turbine casing of the pump. Any leakage of steam between the turbine packing housing and the shaft is arrested by the retainer *e*, which carries three packing rings. The key *f* serves to key the retainer and the turbine wheel to the shaft, and the key *g* keys the brake shoe *h* to the revolving bucket wheel *i* so that the brake shoe revolves with the shaft. The oil slinger *j* revolves with the shaft, and sprays the bearings with lubrication that is carried in the oil well shown. The ball-bearing housing cap *k*, provided with an oil trap, returns the oil to the oil chamber as the lubrication works through the bearing. The pump end of the shaft is carried in a bearing *l* supported by the ball bearing housing *m* that contains an oil trap *n* to return the oil back to the reservoir. The spacing of the bearings on the shaft is governed by the length of the oil flinger *j* and the bearings are maintained at this spacing by the ball-bearing nut *o* in combination with the collar *p* on the shaft *a*. The impeller *q* is screwed on to the water end of the shaft and the water is prevented from working along the shaft by the customary stuffingbox, gland, and nut. The water end of the turbine is closed by the pump casing into which is built the water strainer *r*.

45. The action of the brake will be explained from the diagrammatic view shown in Fig. 35, in which the drum *a* is cast in one piece with the packing housing, and *b* is the brake shoe

keyed to the turbine shaft *c*. This shoe, which is shaped as shown, is $1\frac{1}{4}$ inches thick. The slots *d* are milled in the ends of the shoe as shown. As the shoe revolves within the stationary drum the ends *e* of the shoe move out under the influence of centrifugal force. When the speed exceeds a certain amount, or 6,000 revolutions per minute, the ends will make contact with the drum and the friction developed slows down the speed of the turbine. When the shoe functions, it emits a shrill piercing sound which warns the engineer that the turbine is not delivering water to the heater. With no load, this device is intended to

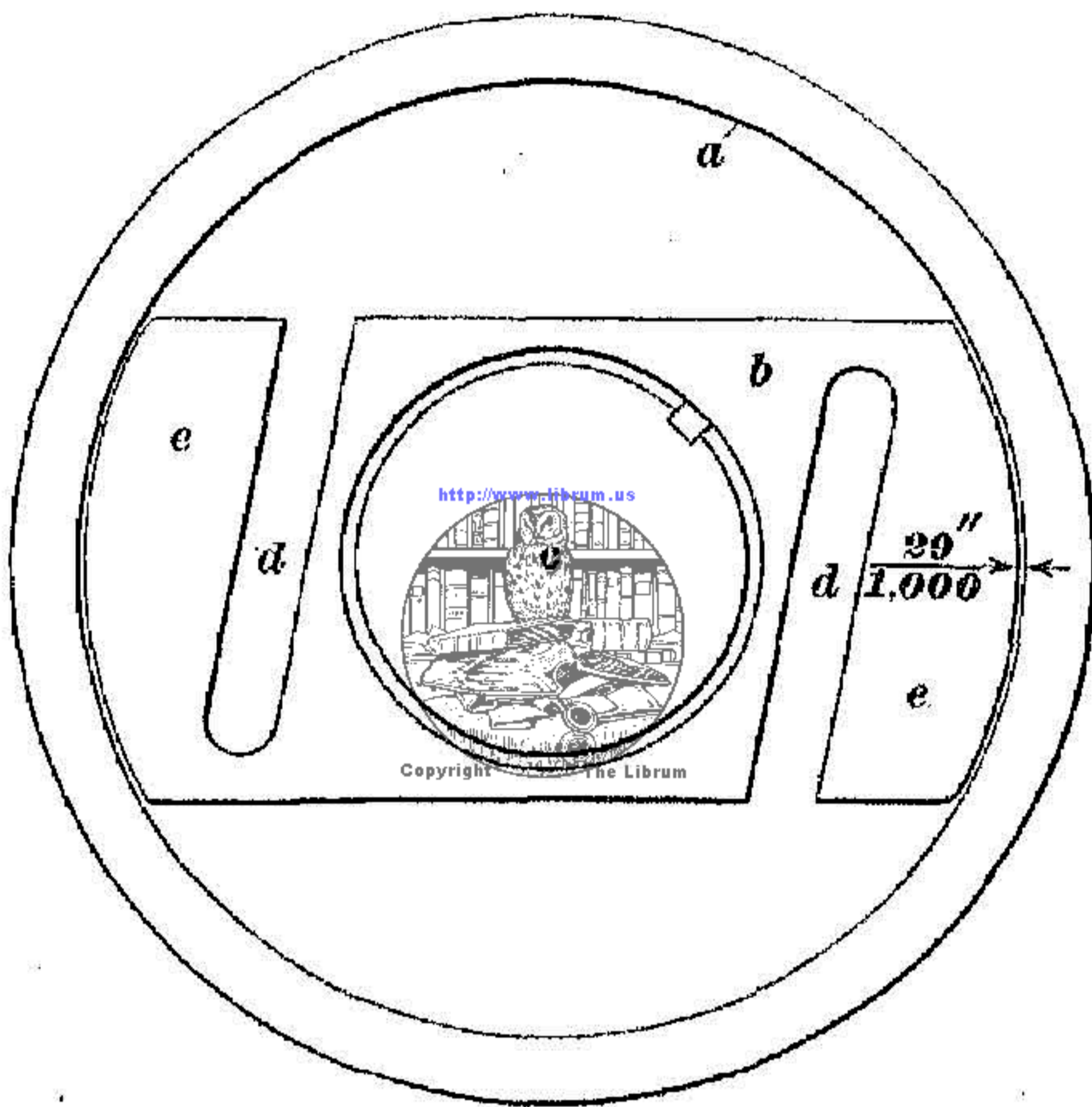


FIG. 35

prevent the turbine from operating at speeds in excess of 6,500 revolutions per minute. As the pump is always operating under a load the brake seldom operates. The normal speed of the pump is 4,500 revolutions per minute.

46. Hot-Water Pump.—In Fig. 36 is shown a sectional view of the mechanism of the hot-water pump. With the piston moving in the direction indicated and at any position except near the end of the stroke, the valve is held to the left. The reason is that chamber *a* contains live steam which exerts a pressure against piston *b*, although this pressure is partly neutralized by the steam that has leaked through the small port *c*. The left end of the valve in chamber *d* is subject to the pressure of the



- | | | | | | |
|---|------------------------------------|------------------------------------|-----------------------------|-----------------------------|---------------------------------|
| 1—Steam Valve | 6—Pump Steam Pipe | 11—Vent Check | 16—Pump Leak-off to Suction | 21—Auxiliary Heater | 26—Line Check |
| 2—Suction Heater Valve | 7—Discharge Pipe to Control Valve | 12—Feed Discharge to Control Valve | 17—Condensate Pipe | 22—Overflow Pipe | 27—Relief Valve |
| 3—Steam Pipe to Control Valve | 8—Leak-off Pipe to Gauge and Vent | 13—Squirt Hose Pipe | 18—Condensate Drain Valve | 23—Vent Pipe | 28—Heater |
| 4—Heater Pipe to Suction and Condensate | 9—Discharge Pipe to Gauge and Vent | 14—Exhaust Pipe to Stack | 19—Suction Pipe | 24—Discharge Pipe to Boiler | 29—Air Valve |
| 5—Control Valve | 10—Vent Pipe | 15—Discharge Pipe to Heater | 20—Pump | 25—Heater Pipe | 30—Exhaust Steam Pipe to Heater |

FIG. 37

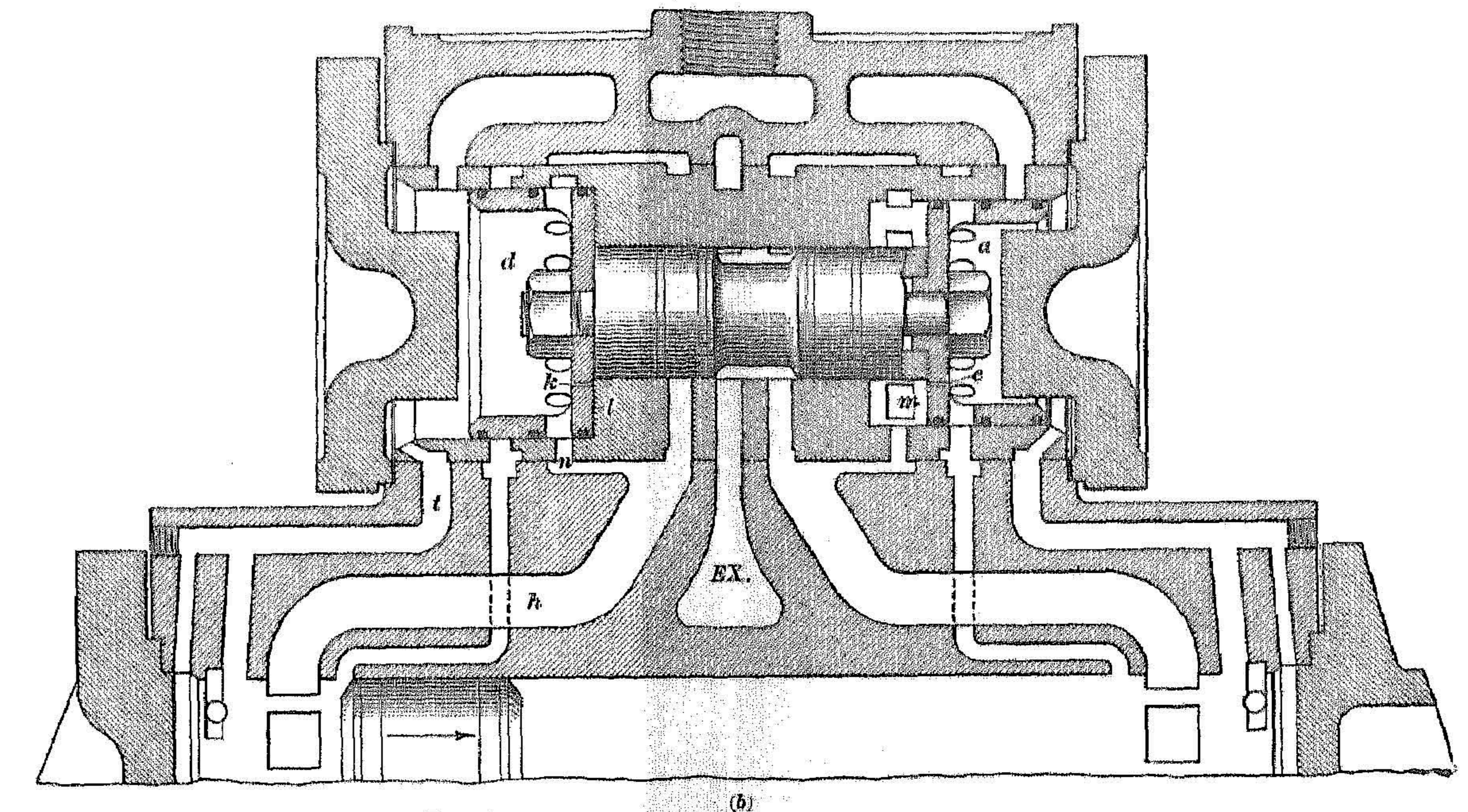
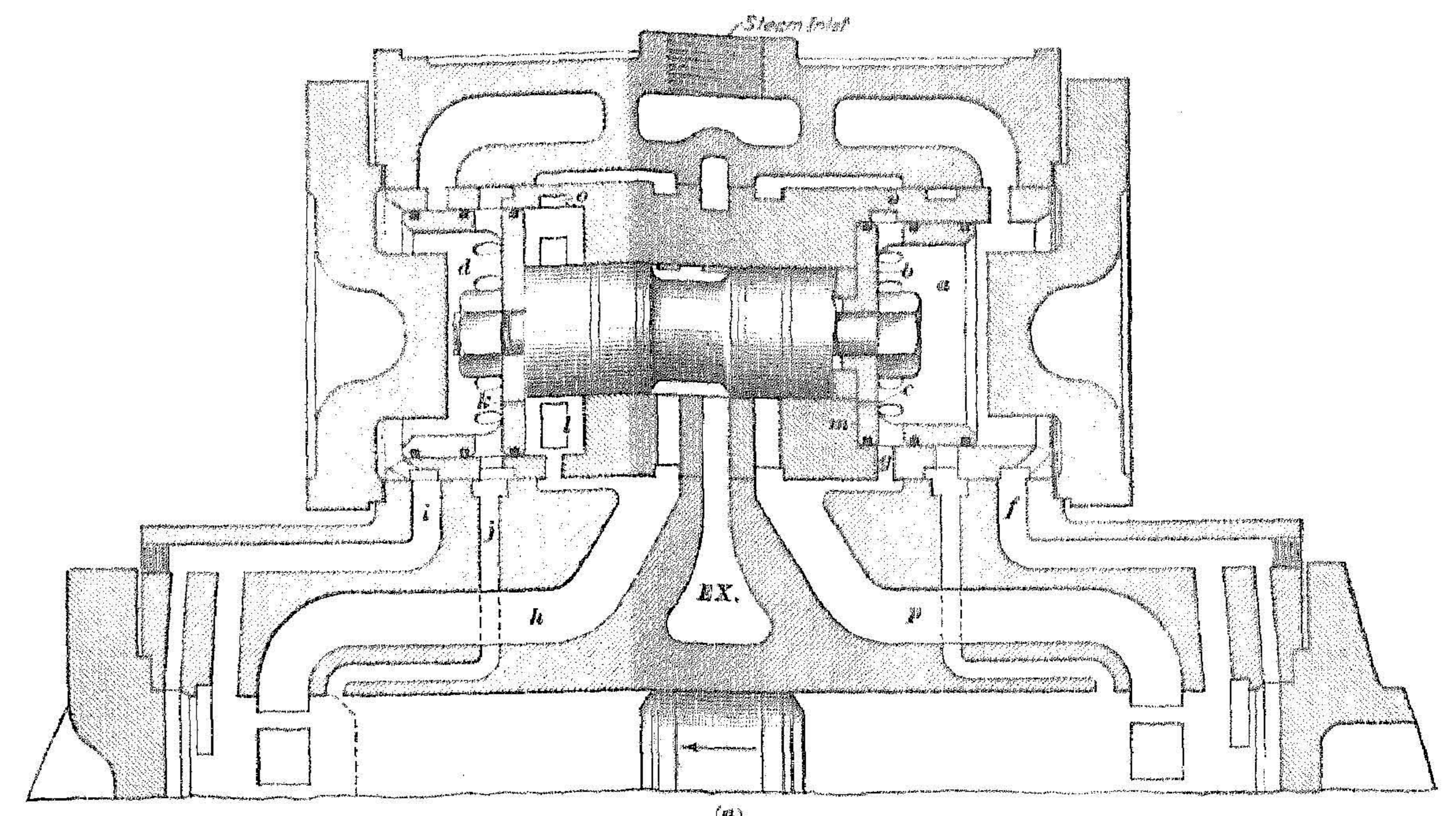

FIG. 38

exhaust steam in the left end of the steam cylinder, so that the valve is held over to the left by the pressure exerted on a central portion of the piston in chamber *a* equal to the cross-sectional area of the spool because of the opposing pressure in the chamber *m*.

With the valve in this position, steam passes to the cylinder through the ports *f* and *g* and the steam in the other end exhausts through the port *h* and a cavity in the valve to the main exhaust port. The ports *i* and *j* supply the exhaust steam to the left end of the valve.

47. The piston as it nears the end of its stroke, as shown by the dotted-line position, Fig. 36 (*a*), opens port *j* and live steam passes to chamber *d*. Any steam that now leaks through the small port *k* cannot develop a pressure in chamber *l* because it is connected to the atmosphere. Hence the pressure on the piston in chamber *d*, combined with the pressure in chamber *m*, exceeds that exerted on the piston in chamber *a*, with the result that the valve moves to the right.

After the valve completes its movement, Fig. 36 (*b*), chambers *a* and *m* fill with exhaust steam and the escape of steam from chamber *l* is checked. The valve is then held to the right by the pressure on an area of the piston in chamber *d* equal to the cross-sectional area of the body of the valve. Briefly summarized, the reason for the reversal of the valve is that the steam, when it is first admitted to either chamber *m* or *l*, escapes to the exhaust until the valve has made the greater part of its stroke.

48. The by-pass grooves *o*, Fig. 36 (*a*), serve to cushion the valve as it nears each end of its stroke. The ports *h* and *p* are principally exhaust ports; the fact that these ports are cut off before the end of the stroke also causes the piston to be cushioned. The ports *i* and *f* supply the greater part of the steam to the cylinder and all of it at the beginning of the stroke.

When there is no mechanical connection between the valve and the piston, precaution must be taken to prevent the valve from stopping central on its seat, in which event steam would be admitted to both ends of the cylinder. To insure positive valve movement, this type of valve is given $\frac{5}{8}$ inch lead and the

left chamber *d* is made of a larger diameter than the right, so that one end of the valve is larger than the other. Therefore, if the valve stops in the center and live steam is admitted to each end of the valve, it will be moved to the right on account of this difference in area.

COFFIN FEEDWATER HEATING EQUIPMENT

49. **General Arrangement.**—The general arrangement of the Coffin feedwater heating equipment is shown in Fig. 37. It comprises a centrifugal pump, a main heater, and an auxiliary heater in the tank. The pump is a high-pressure one, and it forces the water which flows into it by gravity, through the pipe 15 into the heater, and thence through the pipe 24 to the boiler. The exhaust steam from the cylinders enters the heater through the pipe 30 and the condensate and excess exhaust steam is returned through the pipe 17 to the auxiliary heater in the tender. Here the condensate is mixed with the water and heats it as it passes under the heater to the pump; hence the water in the tender is not heated, whereas the water in its passage to the boiler is heated twice.



50. **Heater.**—An exterior view of the heater is given in Fig. 38 and a sectional view is shown in Fig. 39. The heater, which is of the closed type, is placed either in front of the smokebox or is built into it as in Fig. 37, in which position it does not interfere with any smokebox work or the removal of the flues.

The heater is semi-circular in shape, which permits of the maximum length of heater pipes and also provides for expansion without the use of expansion joints. It consists of the casing *a*, Fig. 39, two heads *b*, two tube-sheets *c*, about one hundred and twenty copper tubes, depending on the size of the heater, arranged in five groups, with an inside diameter of about $\frac{1}{2}$ inch, expanded into the tube-sheets by a roller, handhole covers *d*, a baffle *e*, two tube locks *f*, and two tube spacers *g*. The heater heads are of forged steel and are so designed that the feedwater passes through five groups of tubes, each group or pass having tubes approximately 10 feet in length, thus making a total water travel within the heater of about 50 feet. This is shown in the

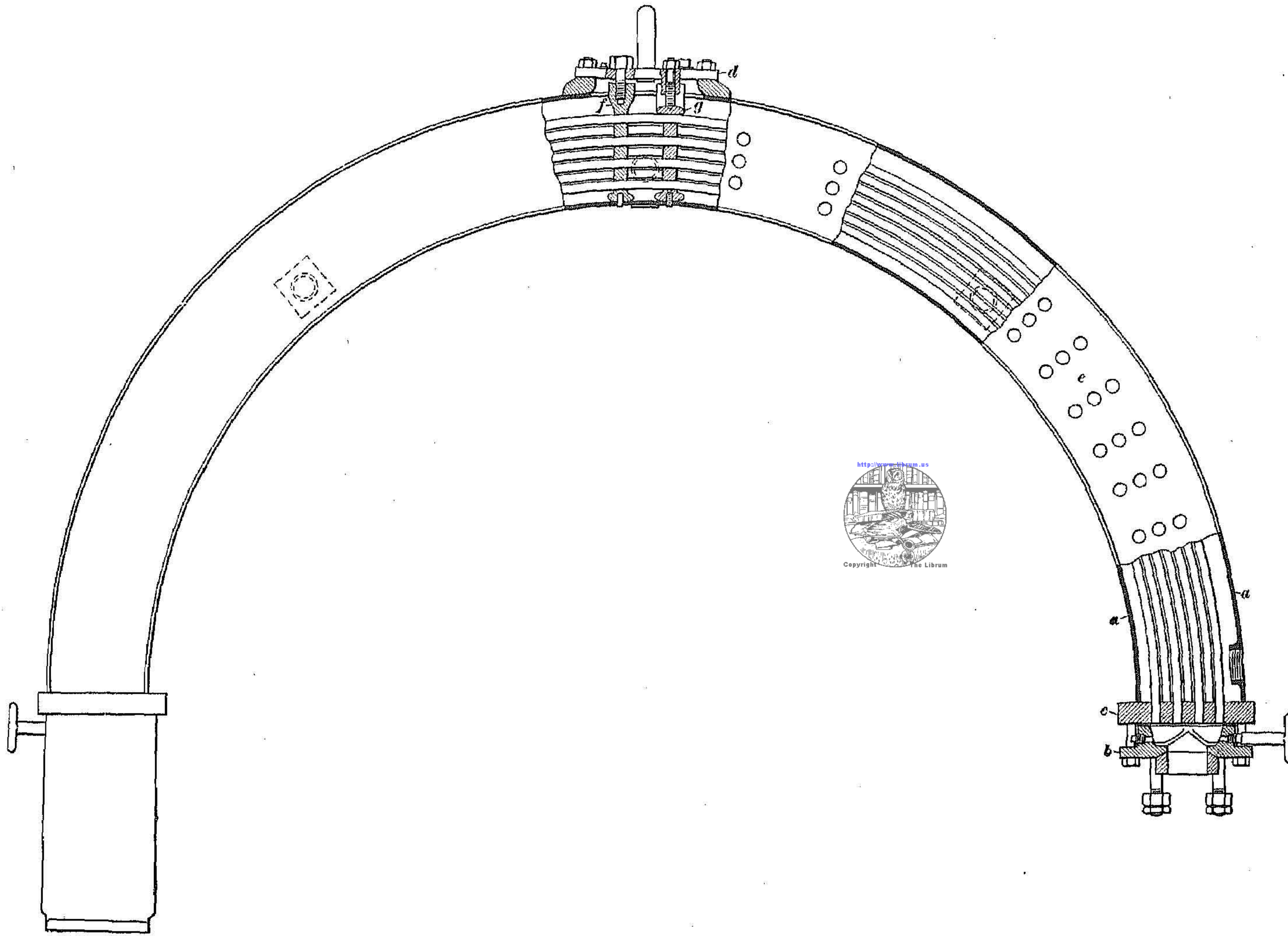

BB 508D 2517



FIG 39

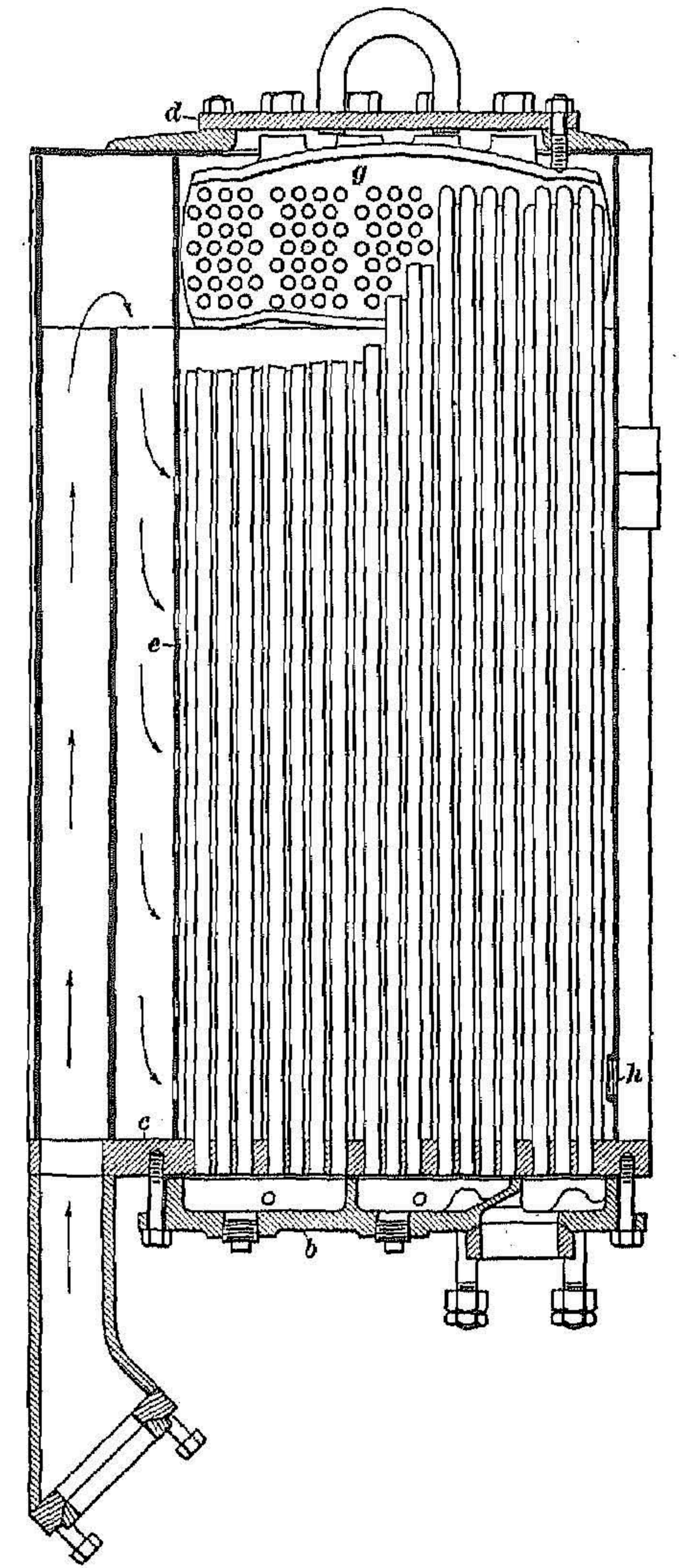

diagrammatic view in Fig. 40, where the heater is shown flattened out to show better the routing of the water.

The exhaust steam enters the steam passage of the heater at the bottom at *a* and flows to the top, where it is admitted to the distribution space between the steam passage and the perforated baffle, through which it flows to the tube space of the heater.

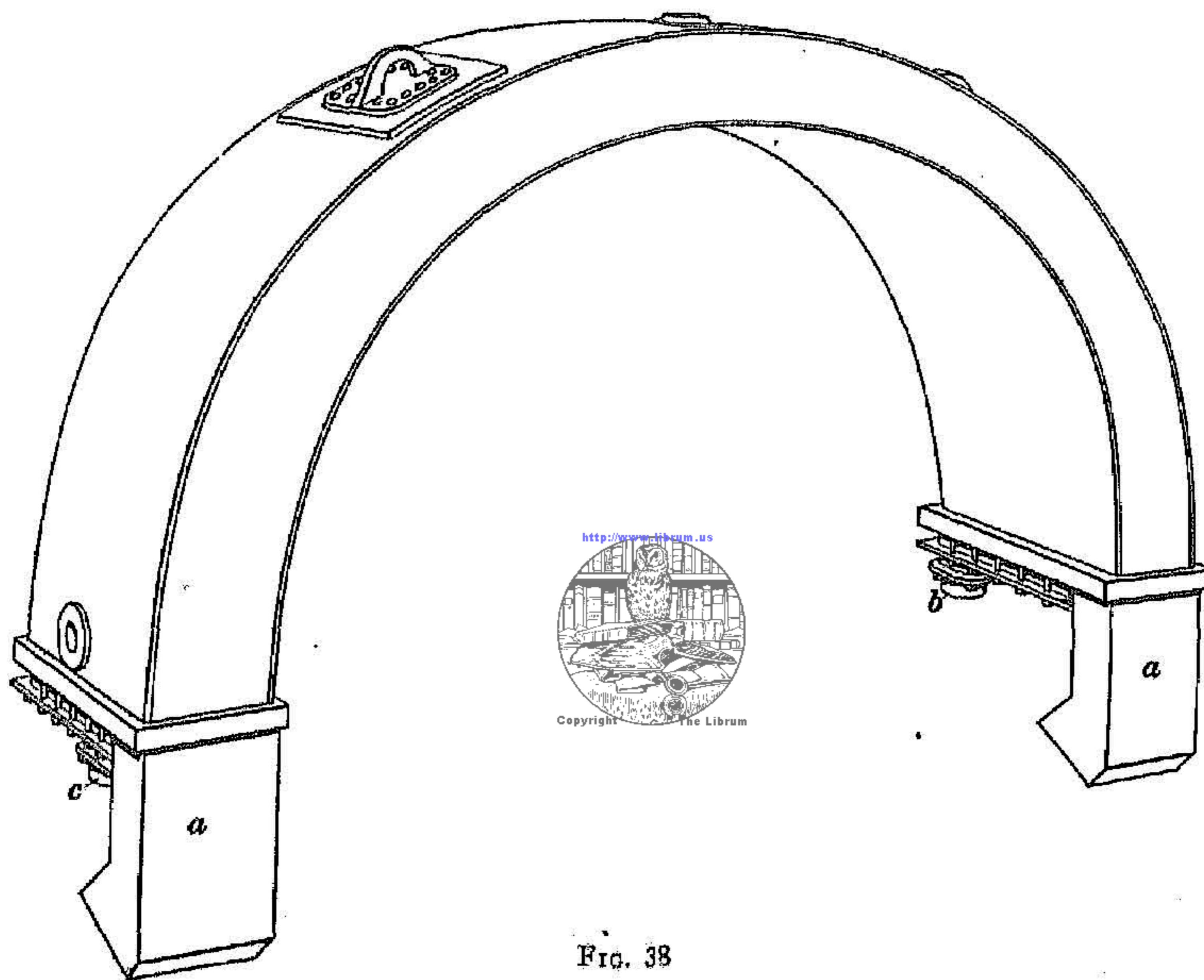

FIG. 38

The water enters the heater at *b* and leaves it at *c*, the passage of the water being shown by the arrows. The first water group is farthest from the steam inlet and the water flows progressively toward the front, while the exhaust steam flows toward the rear. This insures that the hottest water is passing through the tubes surrounded by the hottest steam. The 1½-inch open vent pipe 29, Fig. 37, which extends from the top of the heater, ahead of the stack, is to insure a positive circulation of the exhaust steam toward the rear of the heater, and prevent the formation of air pockets in the steam space of the heater. The condensate flows by gravity down the outside walls of the tubes to the condensate connections *h*, Fig. 39, and *d*, Fig. 40, on each side of the heater.

and thence back to the auxiliary heater. These connections are also designated by the same letters in Fig. 38, except that the condensate connections cannot be seen.

51. Control Valve.—The control valve serves as a throttle valve for the pump, that is, by means of it the pump can be run at a speed that will maintain the desired water level in the boiler. In addition, it will operate automatically and limit the supply of steam to the pump to a limited amount in the event of any interruption to the water supply, such as low water in the tender,

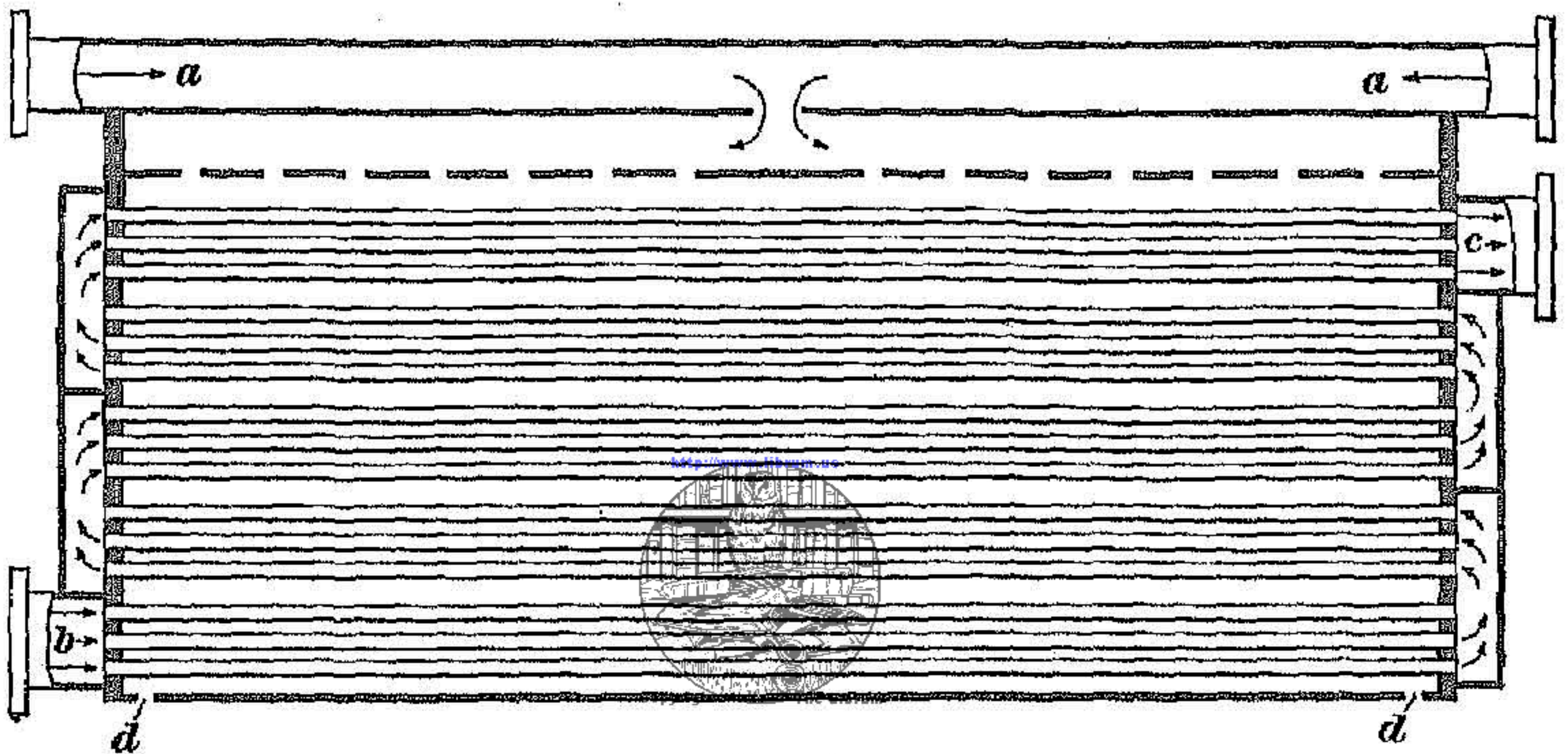
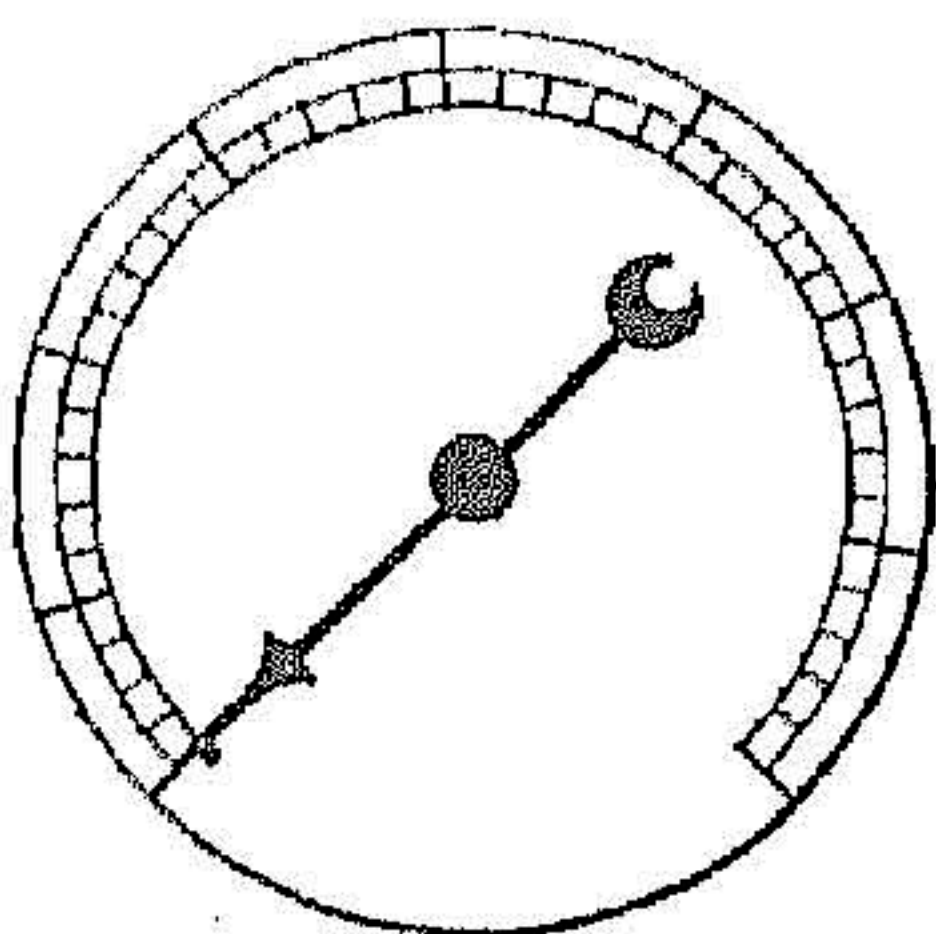
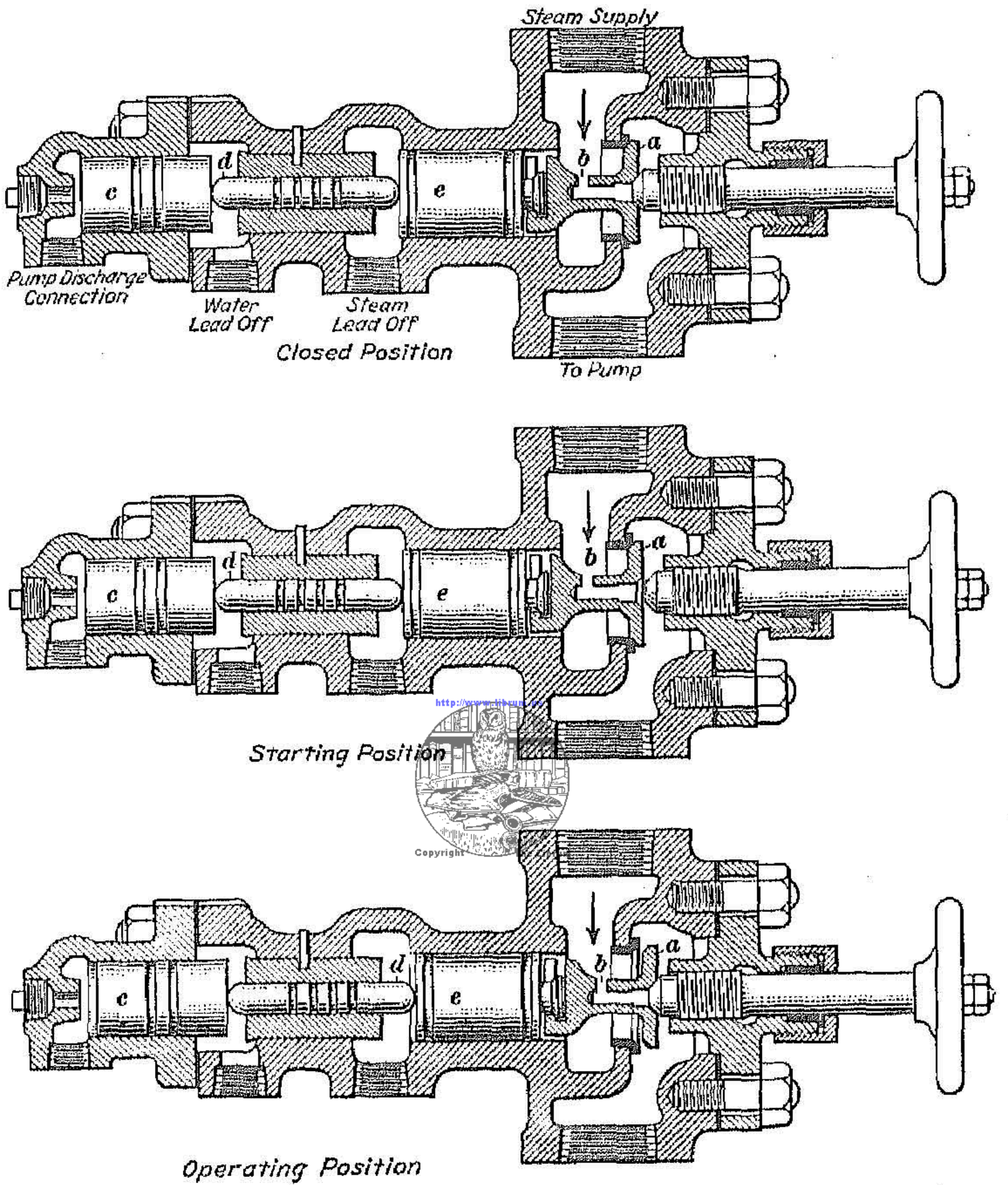

FIG. 40

tank valve closed or strainer plugged. It is only when the control valve is not operating that the governor will cut in and stop the pump.

52. Three sectional views of the control valve are shown in Fig. 41 with the various pipe connections indicated. Turning the hand wheel toward open position moves the end of the spindle away from the disk *a* and permits steam to flow to the pump through the starting port *b* drilled in the side of the disk. The pump now starts rotating and a pressure builds up in the water end of the valve, which moves the water piston *c*, the piston rod *d*, and the steam piston *e* to the right and causes the disk to unseat. As soon as the discharge pressure, indicated by the black hand of the duplex gauge, exceeds the pump steam pressure, indicated by the other hand, which is red, the disk will continue to open, after which both hands will go up together



Closed Position

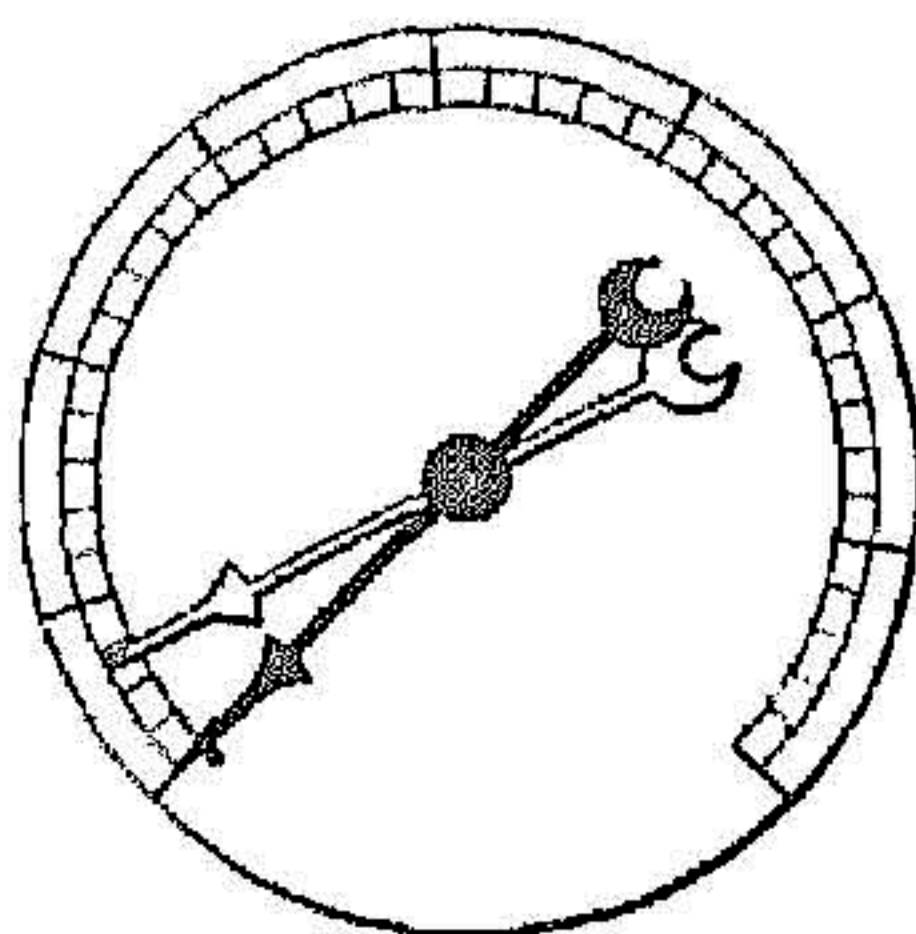

Starting Position

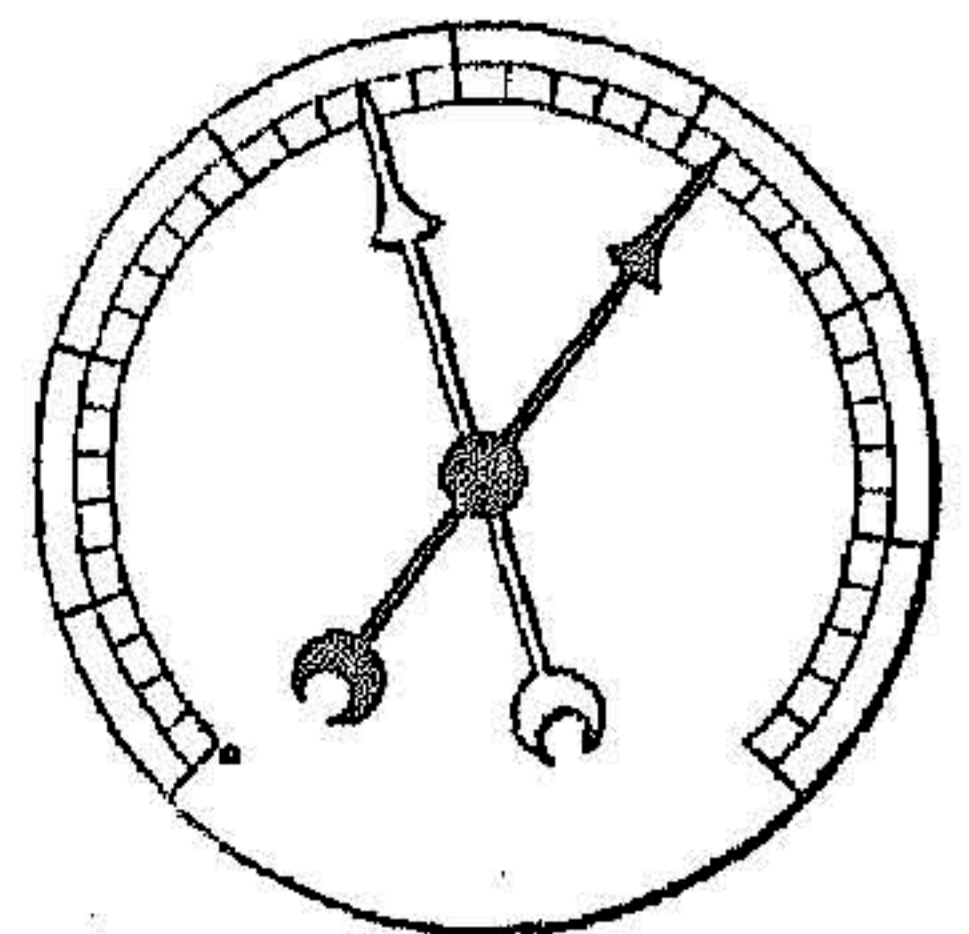

Operating Position

FIG. 41

to operating pressures. With a boiler pressure of 200 pounds, the red hand will indicate about 185 pounds pressure, and the black hand about 260 pounds water pressure. Any decrease in the steam pressure will automatically cause a decrease in the water pressure and the disk will move nearer to its seat. With the water supply interrupted the discharge pressure will drop, the steam pressure on the disk will then move the pistons *e* and *c* to the left and seat, thereby limiting the steam supply to the pump to the capacity of the starting port.

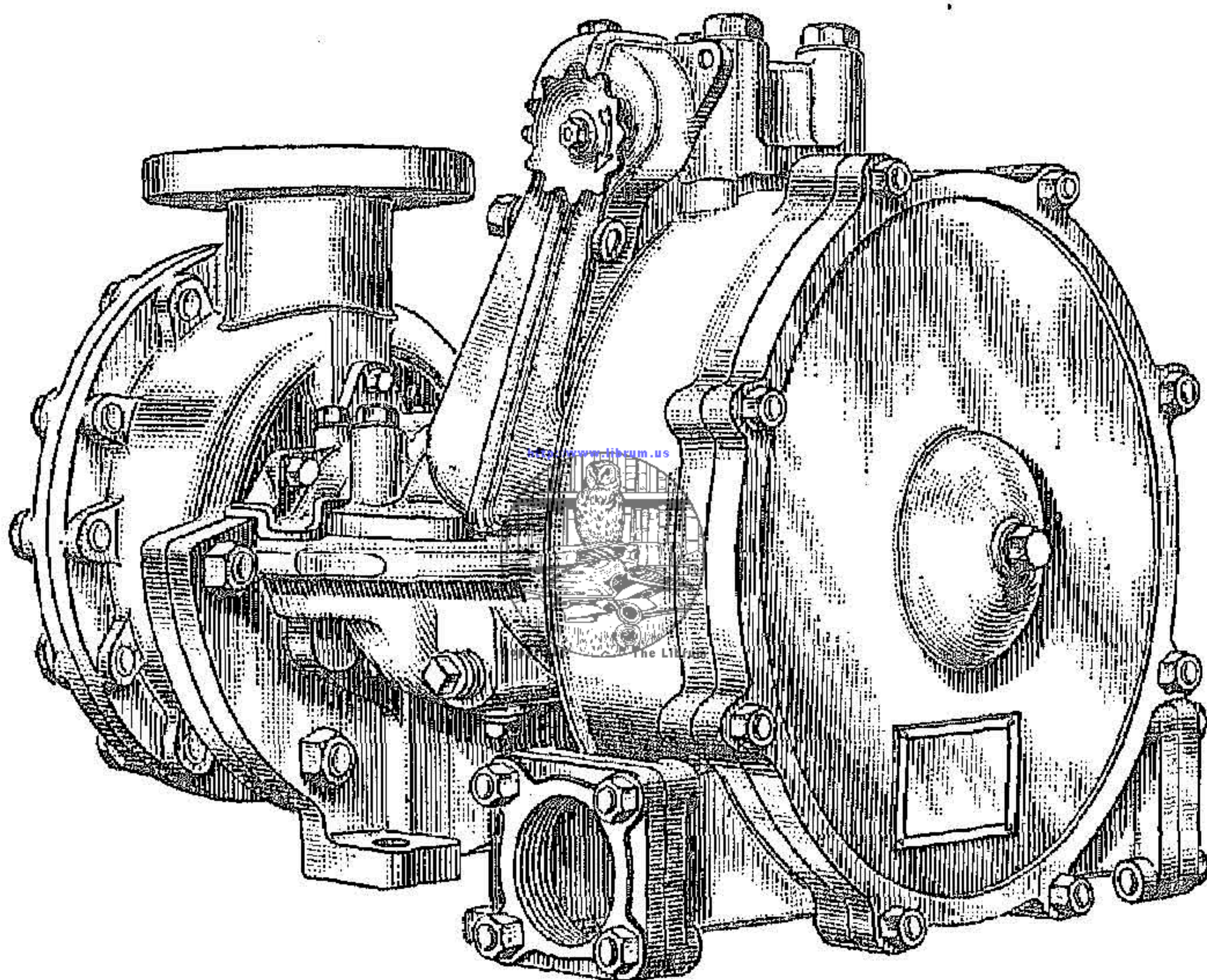

FIG. 42

53. **Vent Check.**—The purpose of the vent check 11, Fig. 37, located at the top of the feed-line branch is to prevent the pump from becoming air- or steam-bound when not in operation; also, it insures that the pump is primed at all times.

54. **Relief Valve.**—The purpose of the relief valve 27, Fig. 37, in the pump discharge line between the line check and the heater is to protect the system from excess pressure in case the pump is started with the boiler check closed.

55. **Pump.**—A perspective view of the Coffin feedwater pump is shown in Fig. 42, and a sectional view in Fig. 43. The

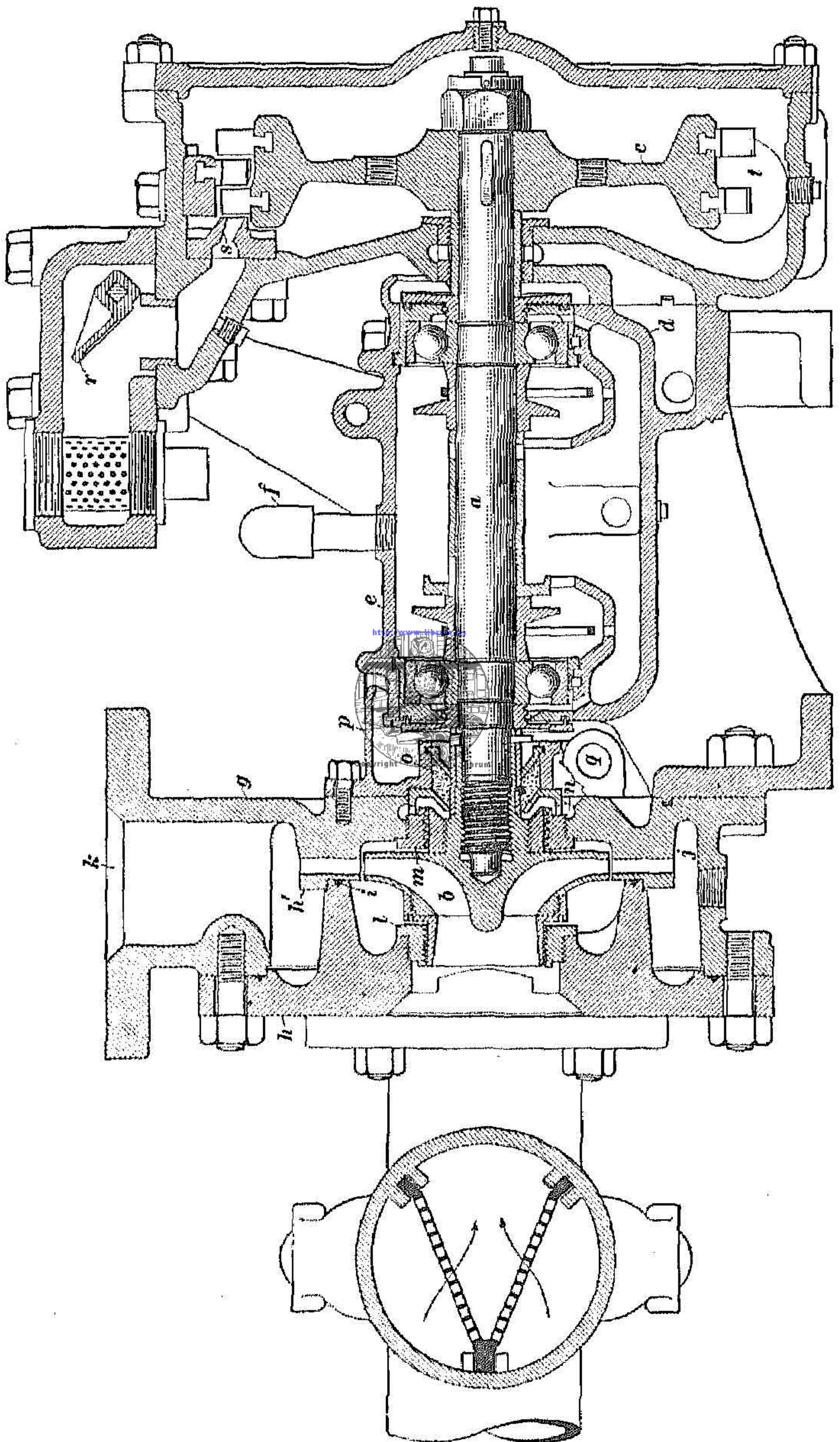

FIG. 43

water end of this pump is of the turbine type already explained. The shaft *a* with the impeller *b* on one end and the steam turbine or bucket wheel *c* on the other end is carried on ball bearings, supported by the bearing casing *d* provided with a mounting base; the bearing cap *e* holds the outer races of the ball bearings in their proper position. The casing also serves as a reservoir for oil. Any steam that may leak into the casing is discharged through the vent *f*. A pump casing *g*, which is bolted to the bearing casing, surrounds the impeller, and a suction head *h*, which closes the end of the pump casing, makes a joint with the pump suction pipe. Inlet vanes in the head serve to screen the water. The diffusion ring *h'*, which is used with the turbine type of pump, is secured to the pump casing and a water-tight joint between the suction head and the diffusion ring is made

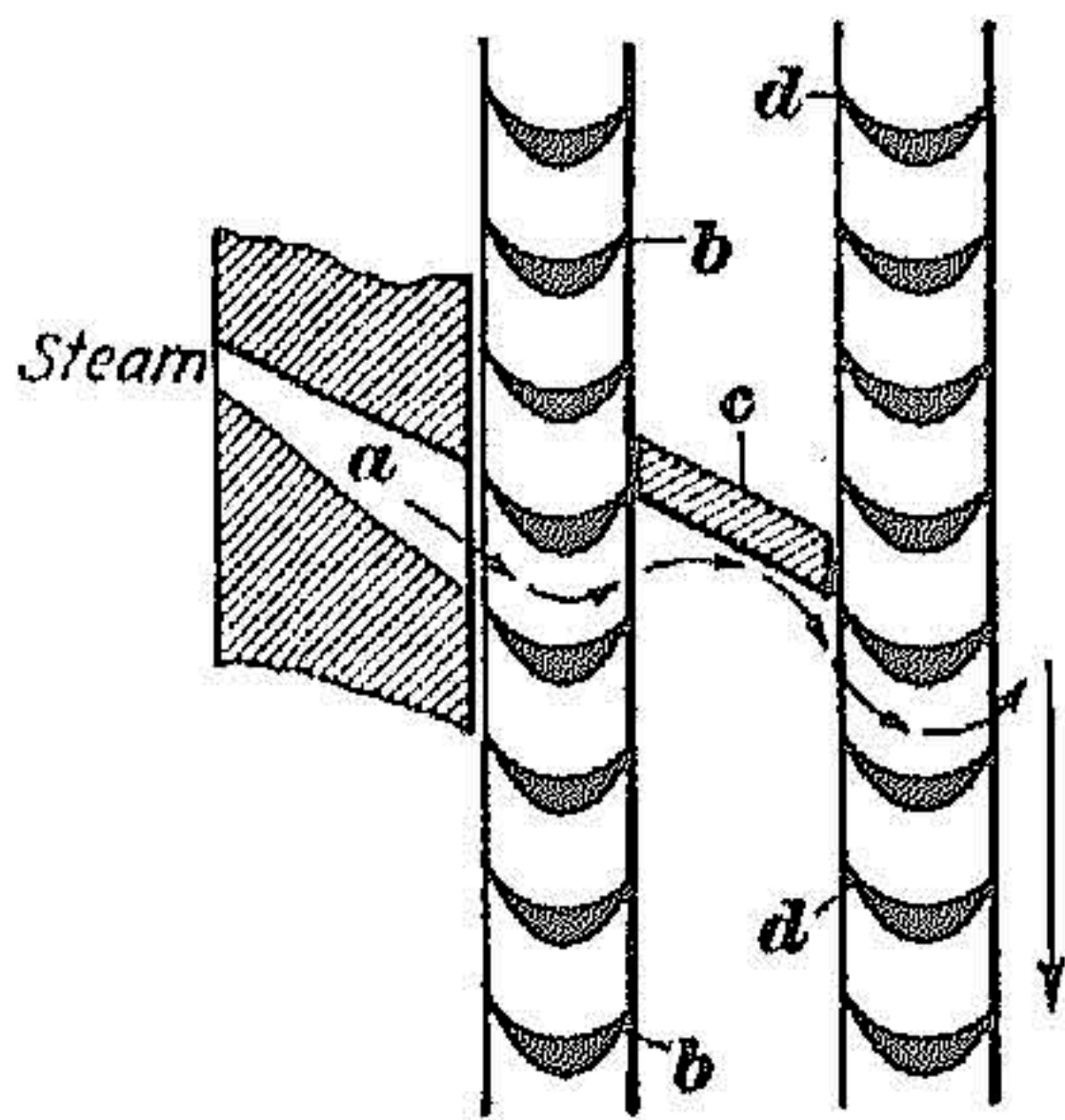

FIG. 44

by the copper-wire gasket *i*. The water enters the open mouth of the impeller, and being caught by the rapidly moving impeller vanes is discharged at a high velocity to the passages in the diffusion ring, where it is changed gradually into pressure. The space *j* surrounds the diffusion ring and is filled with water under pressure that is discharged through the flanged connection *k* into the heater and thence to the boiler. The

wearing ring *l* prevents the entry of water into the pump casing except into the mouth of the impeller; any water that may pass the wearing ring *m* leaks out to the atmosphere at *n*. The packing *o* prevents the entry of any water into the bearing casing. Access to this packing is obtained through the pump packing box *p*. Any water that accumulates in this box is drained out through the drain.

56. The bucket wheel is surrounded by a casing that is provided with a cover. The wheel has two circles of blades or buckets inserted in the circumference of the wheel. Steam first passes through the control valve in the cab and then passes through the strainer and the open governor valve *r*, Fig. 43, to

the steam nozzle *s*. The nozzle performs the same function as the steam nozzle in an injector, that is, it is so shaped as to expand progressively, the steam thereby lowering its pressure and hence increasing its velocity. The action of the steam jet on the wheel can be more readily understood from Fig. 44. After leaving the nozzle *a* the steam impinges at an angle against the first circle of buckets *b*, causing the wheel to turn in the direc-

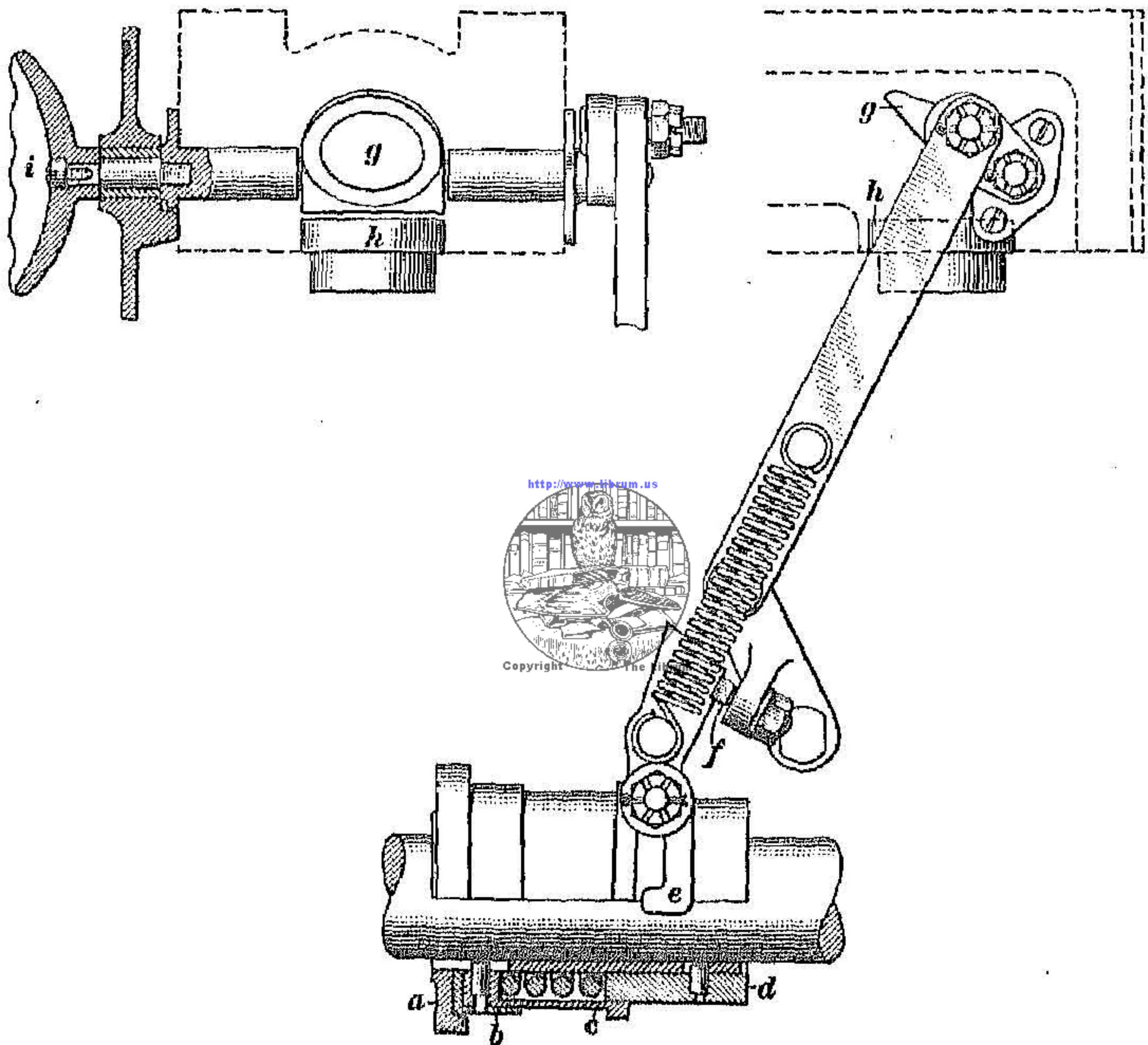

FIG 45

tion of the arrow. On leaving this circle of buckets, the flow of steam is changed in direction; to make further use of it, the direction of the flow is changed to a more acute angle by the stator or stationary blade *c*, attached to the housing, which directs the flow of steam to the second circle of buckets *d*. The steam then discharges to the exhaust through the opening *t*, Fig. 43.

Impellers that take water from one side only are known as the single-suction type. The partial vacuum formed in the

suction end has a tendency to cause the shaft to move laterally in that direction. The ball bearings are arranged to resist lateral movement. With double impellers, the shaft is balanced and any tendency for lateral movement does not exist.

57. Governor.—The governor used with the Coffin pump is not a governor in the usually accepted sense; this function is performed by the control valve. In the event of the failure of the control valve to regulate the speed of the pump, the governor operates and stops the pump, so that the governor may be considered as a tripping device, and as it does not reset automatically, it must be reset by hand.

The governor arrangement, Fig. 45, comprises the governor body *a* on the main shaft, two governor weights *b*, a governor spring sleeve *c* that encloses a spring, and a governor spring follower *d* that acts as a base for the spring when it is compressed.

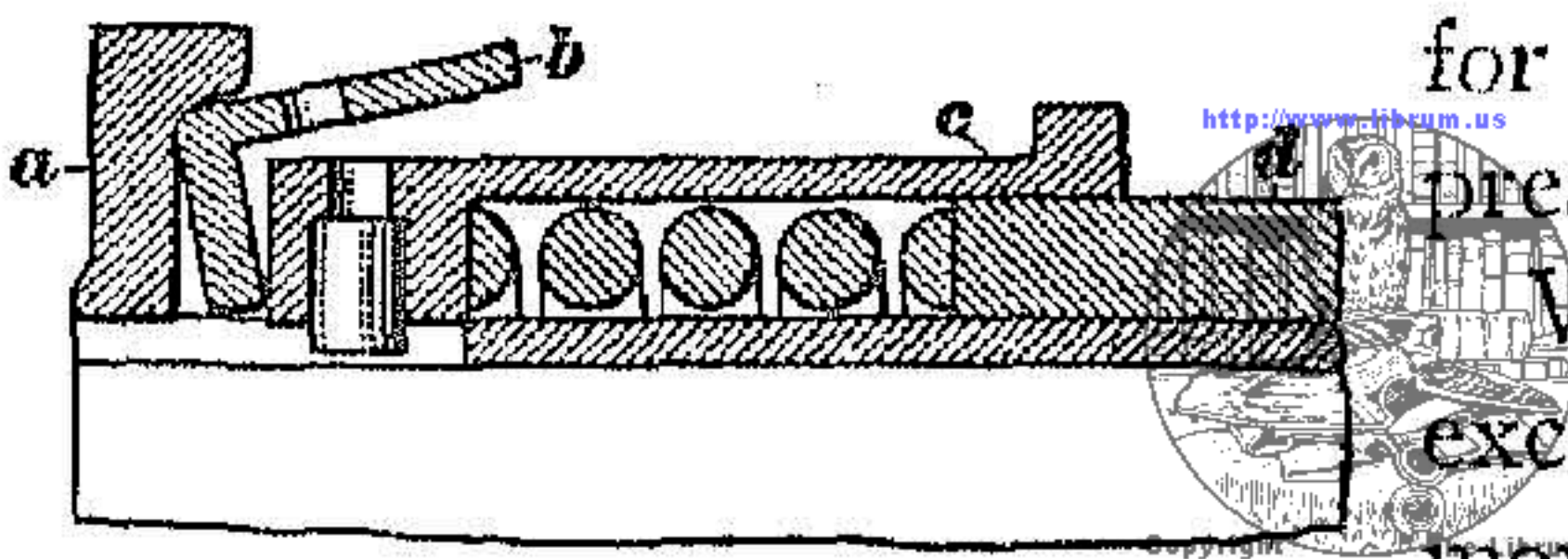

FIG. 46

When the shaft revolves at an excessive speed, the weights move out as shown in the diagram in Fig. 46, so that the lip of the weight *b* pushes against the spring sleeve and compresses the spring, thereby bringing the collar on the sleeve into contact with the trip trigger *e*, Fig. 45. This action disengages the point *f* of the trip lever screw from its seat in the trip trigger; the trip spring then pulls the trip rod as well as the trip valve *g* down to its seat *h*, thereby shutting off the passage of steam to the pump.

To open the valve again, which is known as resetting the governor, the control valve must be closed tight and after waiting for about 1 minute to permit the steam on the trip valve to reduce in pressure by condensation, the resetting wheel *i* is turned clockwise. This lifts the trip valve off its seat against the tension of the trip spring and pulls the trip lever up until the end of the screw *f* again snaps into its seat on the trip trigger.

The resetting wheel is placed on the inside of the pump so as to lessen the liability of its being tampered with.

OPERATING INSTRUCTIONS

58. **Starting Pump.**—Before starting the pump when desiring to feed the boiler, be sure that the tank valve, the turret valve, and boiler check are wide open. Then open the control valve and observe the movement of the hands on the duplex gauge. The red hand should rise slowly 25 or 50 pounds, after which the black hand should rise to the same point. Both hands should then rise to the operating pressure, which will be about 185 pounds on the red hand and 260 pounds on the black hand for a boiler pressure of 200 pounds. Regulate the water supply by using the control valve only. When not feeding the boiler, idle the pump with 15 or 20 pounds on the red hand of the gauge.

59. **Operating Pump On the Road.**—After starting the pump at the beginning of a run it is sometimes not advisable to shut it off entirely until the completion of the trip. In such an event, close the control valve until 15 or 20 pounds is indicated by the red hand of the gauge. This keeps the pump turning over slowly and ready to go to work instantly. There is no danger of flooding the boiler by this procedure, as no water passes to the boiler until the black hand rises above boiler pressure.

60. **Resetting Pump Governor.**—To reset the pump governor, close the control valve tight and, after waiting about one minute, turn the resetting wheel near the pump steam chest clockwise by hand only to the end of its travel, or about one-half turn, then release it. A spring will then return the resetting wheel to its original position. If the wheel can then be turned easily, the pump is reset. If the pump cannot be reset by hand, the control valve is leaking and must be ground in. Under no circumstances should the trip mechanism be blocked or tied open or adjustments made at engine houses.

61. **Protecting System From Freezing.**—To protect the system from freezing, open the warming valve in the cab and also at the front end. Draining the system is not necessary unless the engine is stored, or dead, provided both warming

valves are left open. Idle the pump with 15 to 20 pounds on the red hand of the duplex gauge.

62. **Pump Fails.**—If the pump fails on the road, open the condensate drain valve and close the turret steam valve to the pump. Leave the condensate drain valve open or the water in the tank will heat. If the pump becomes noisy, report it at once, as the pump must be changed.

DISORDERS

63. **Red Hand Approaches Boiler Pressure But Black Hand Does Not Rise to Working Pressure.**—This condition is caused either by the pump being tripped or by the steam strainer in the pump steam chest being plugged.

64. **Both Gauge Hands Rise to 25 or 30 Pounds Only.**—If both gauge hands rise to 25 or 30 pounds and will go no farther, the water connection to the control valve is frozen, the control valve pistons are stuck or the tank valve is closed.

65. **Red Hand Rises to 25 or 30 Pounds and Black Hand Remains at Zero.**—This condition is caused by steam leaking by the disk in the control valve.

66. **Relief Valve in Discharge Line Opens.**—If the relief valve opens in the discharge line, the boiler check is closed, the discharge line or heater tubes are obstructed or the relief valve is out of adjustment.

67. **Tank Water Heats.**—The tank water heating may be caused by the condensate cock being kept closed with the pump not in use, also boiler and line checks may leak.

68. **Pump Will Not Supply Boiler.**—First make sure that the tank valve, pump turret valve, and boiler check are wide open, also that the pump steam strainer, suction strainer, and control valve are clean. Then open the control valve wide and if the pump delivery pressure does not rise to within 20 pounds above boiler pressure, the tubes of the main heater may be obstructed or leaking. The pump should be replaced if the

discharge line and the tubes of the heater are tight and free from obstructions.

69. **Causes for Pump Stopping.**—If the pump stops, either the water supply has failed or the pump has tripped, in which event the black hand will drop immediately to zero. In case of a pump failure, open the condensate drain and close the turret valve.

EXHAUST-STEAM INJECTORS

WATER-FORCING APPARATUS COMPARED

70. The reciprocating pump, the centrifugal pump, and the injector are heat-operated devices used to put water under pressure. The term *heat* as here used does not refer to the familiar sensation of heat; instead, it refers to the incessant movement of the minute particles of which all bodies are composed. Steam consists of particles of water in intense vibration, thrown off from heated water, and when confined these particles exert a pressure on the walls of the confining vessel. By means of proper apparatus, heat can be used to do work and, although pressure is commonly associated with the performance of work, yet it should not be overlooked that heat is the real agent, pressure being merely the result of heat.

The appliances already referred to are designed to change heat into work, but the manner in which this is done varies somewhat with each one. With the ordinary type of water pump, the development of pressure is accomplished by steam pressure that is transmitted through the medium of pistons to the water. With a centrifugal pump the action is different; the water is given a high velocity but very little pressure by the impeller; the pressure is developed by directing the fast-moving water thrown off by the impeller against the slow-moving water in the discharge pipe. The action of an injector does not differ greatly from that of a centrifugal pump. However, instead of steam being used to give velocity to the water through the medium of a rapidly rotating impeller, velocity is imparted to the water by permitting the steam to mingle with it, thus dispensing with the employment of any intermediate mechanism such as the pistons of a reciprocating pump or the turbine wheel and the

impeller of a centrifugal pump. In other words, the transformation of heat into the performance of work is accomplished with an injector without the introduction of a single moving part.

71. With an injector, steam is caused to expand gradually in its passage through the steam nozzle and in so doing it has its normal velocity increased by about four times. Such an action can only be obtained at the expense of heat, this term meaning the intense movement in every direction, or the vibration of the steam particles. The steam then discharges from the nozzle at an extremely high velocity but at a comparatively low temperature, and hence at a low pressure. When the fast-moving but low-pressure steam is brought into contact with and condenses with the water, a large portion of the velocity of the steam will be imparted to the water, the result then being a jet of water moving at a high velocity and at a low lateral pressure. From now on, the action of an injector does not differ from that of a centrifugal pump. By directing the fast-moving jet against the comparatively slow-moving body of water in the discharge pipe, the shape of the nozzle next to this pipe being such as to accomplish a gradual lowering of the velocity, the water in the discharge pipe immediately increases in pressure to such an extent as to open the boiler check-valve and enter the boiler. The column of water in the discharge pipe may be compared to an anvil that is being incessantly bombarded by particles of water moving at a high velocity.

PRINCIPLE OF OPERATION

72. The operation of an exhaust-steam injector is based on the fact not always recognized that there is practically no difference between the velocity of low-pressure steam and high-pressure steam when discharging through an orifice of the same size. Also, the number of heat units, heat being the agent that causes an injector to force the water, does not vary widely with high- and low-pressure steam.

With two boilers, one under a pressure of 100 pounds to the square inch and the other under a pressure of 200 pounds, and with an orifice of the same size in each, the velocity of the discharge from both is almost the same.

However, there is this difference: about double the quantity of steam, by weight, discharges from the high-pressure boiler because the steam in this boiler is about twice as dense as the steam in the other one. For the same weight of steam to discharge from the low-pressure boiler, its orifice must be made about twice the size of the one in the high-pressure boiler. Now the velocity that steam imparts to water depends on the weight of the steam and its velocity, so that by using low-pressure steam and providing the injector with a large nozzle, practically the same velocity can be imparted to a jet of water as with a high steam pressure and a small nozzle.

73. In practice an exhaust-steam injector, or an exhaust feedwater heater, as it is sometimes called, does not operate exclusively with exhaust steam when the locomotive is in operation. In addition, a supplementary jet of live steam is used to fill in the intervals between the exhausts, thereby insuring more uniform operation. It will be convenient to regard the supplementary jet of live steam as being mostly concerned with imparting the required velocity to the water, and the exhaust steam as a medium to heat the water. As already pointed out, the amount of steam used to force the water is very small in comparison with that required to heat it, so that the drain on the boiler is insignificant when the water is heated by exhaust steam. When regarded in this sense, the exhaust-steam injector is a feedwater heating device, which provides the same economies as the equipment already considered.

74. The exhaust-steam injector is almost as old as the live-steam injector, which was introduced in 1859. The first record of the patenting of an exhaust-steam injector was in 1867. It has, along with feedwater heating equipment, come into prominence in recent years owing to the fact that the size of boilers is approaching the maximum, thus rendering it imperative to economize as far as possible on the use of steam for steam-driven appliances on the locomotive, and making more of it available for the movement of trains. Any saving of steam is of course equivalent to an increase in the steam-generating capacity of the boiler without increasing its size.

ELESKO-SFX EXHAUST-STEAM INJECTOR

75. **Description.**—The arrangement of the Elesco SFX-type exhaust-steam injector on the locomotive is shown in Fig. 47 and a diagrammatic view of the injector with the valves and the piping required for its operation is shown in Fig. 48. The injector body, which is made in two parts which contain a spring-loaded exhaust valve *a*, a supplementary nozzle *b*, a main steam nozzle *c*, which can be moved lengthwise by the water regulator *d*, a draft nozzle *e*, a vacuum nozzle *f*, a combining nozzle *g* supplied with a hinged flap *h* and a delivery nozzle *i*. The injector body is provided with a water valve *j* and an overflow valve *k*, the same as a live-steam injector. Exterior to the injector is a relay valve *l*, a relay piston *m*, an automatic valve *n* and a change-over diaphragm *o*. This diaphragm is held up by exhaust steam from the pipe *p*; with the diaphragm up, the pin valve *q* closes the end of pipe *r*.

76. This injector differs essentially from a live-steam injector in that it may be considered as having two combining nozzles, namely, the draft nozzle and the vacuum nozzle, which together form one combining nozzle, and the combining nozzle proper. The main steam nozzle performs the same function as the steam nozzle of the ordinary injector, but it must have a greater cross-sectional area because, with low-pressure steam, the nozzle, as already pointed out, must be made larger in order to deliver the required weight of steam. The separation of the draft nozzle and the vacuum nozzle is an exclusive feature of this type of injector and serves a highly important function, as the opening between these nozzles serves to reintroduce the low-pressure steam to the water and so increases its velocity. Were it not for constructional difficulties, the vacuum nozzle and the combining nozzle just ahead of it could be made equally as well in one part. The delivery nozzle serves the same purpose as with the ordinary injector.

77. **Exhaust-Steam Operation.**—When operating with exhaust steam (see Fig. 49), the large pipe that is connected to the exhaust passages in the cylinders as well as the large

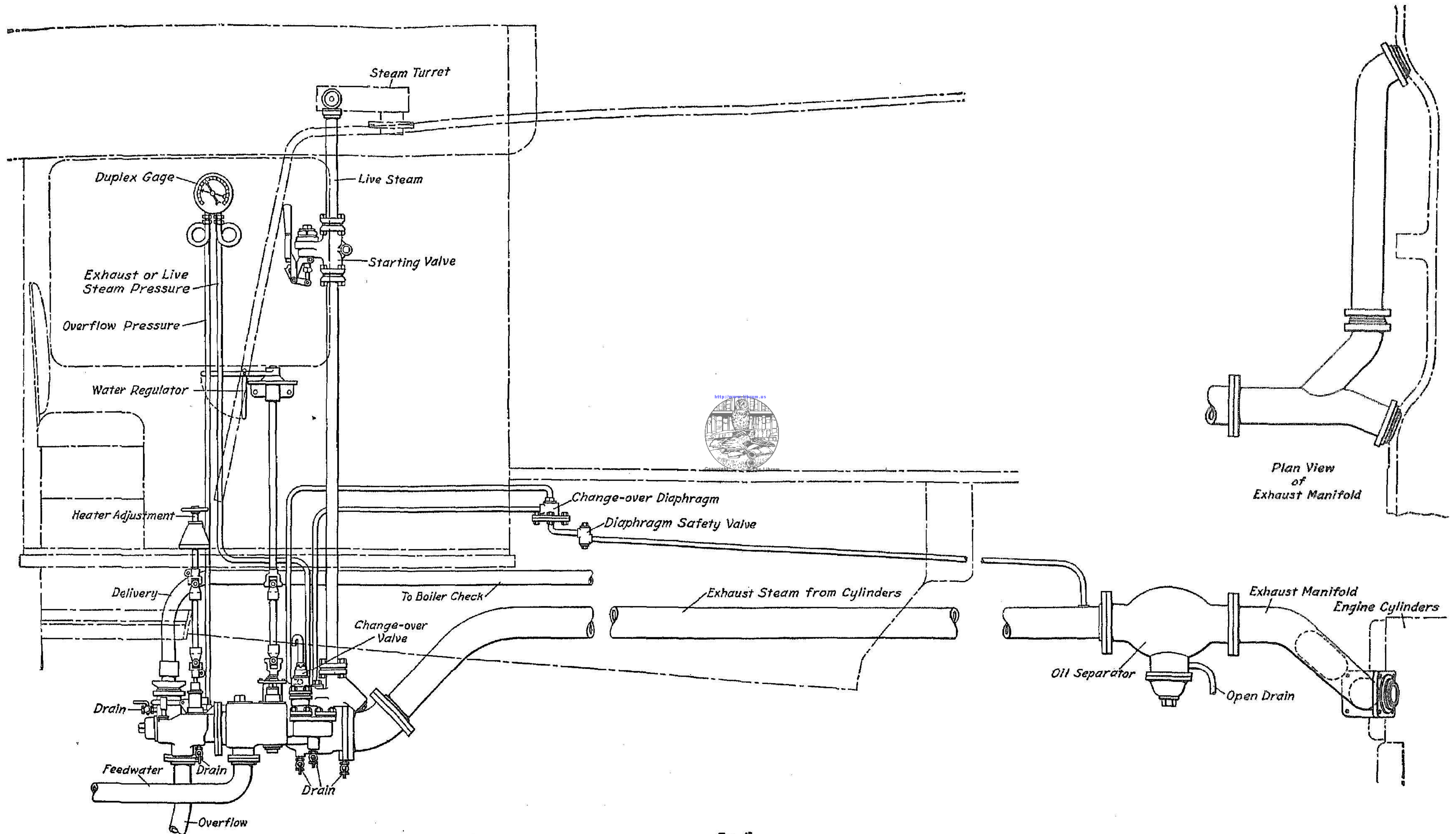

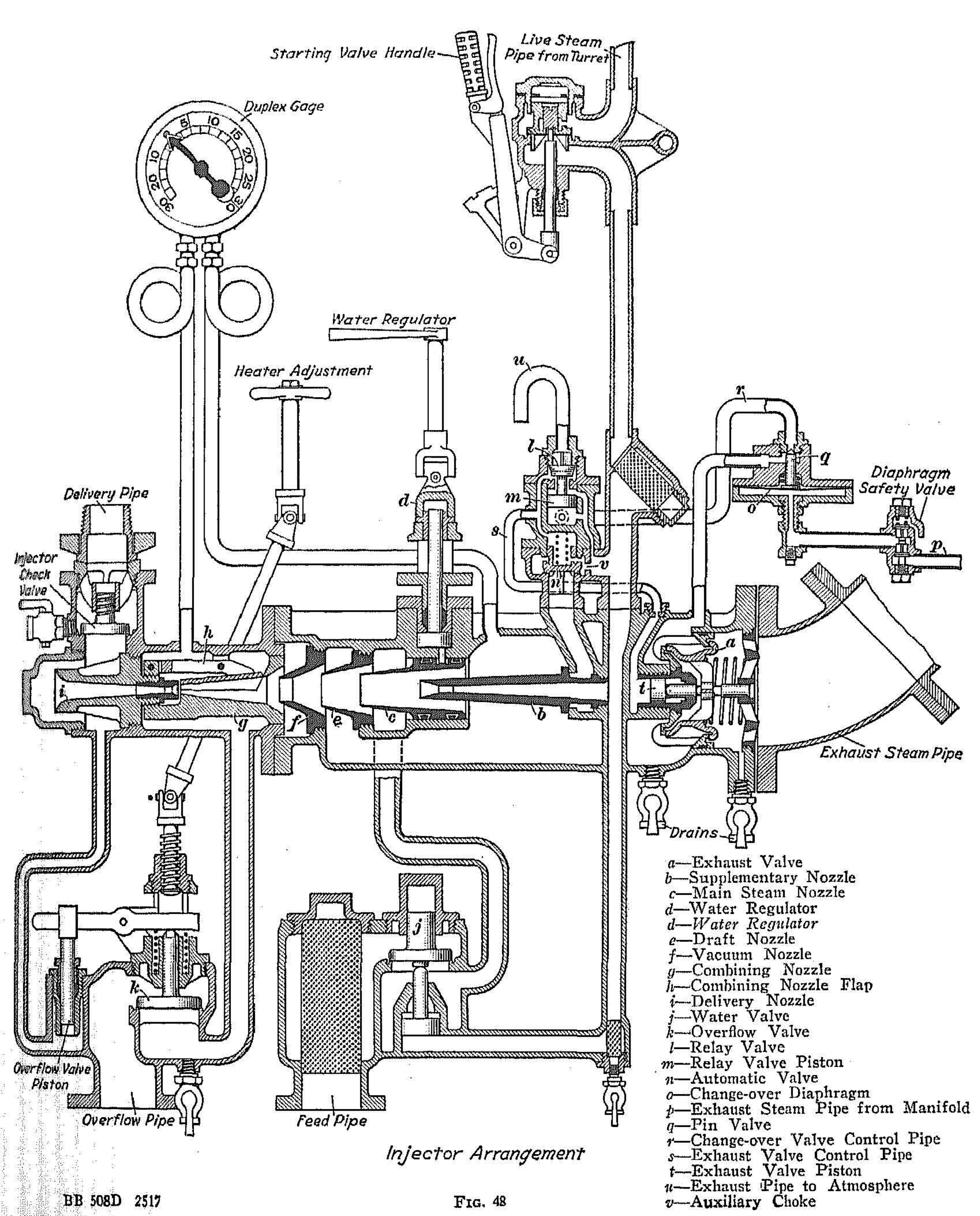

FIG. 48

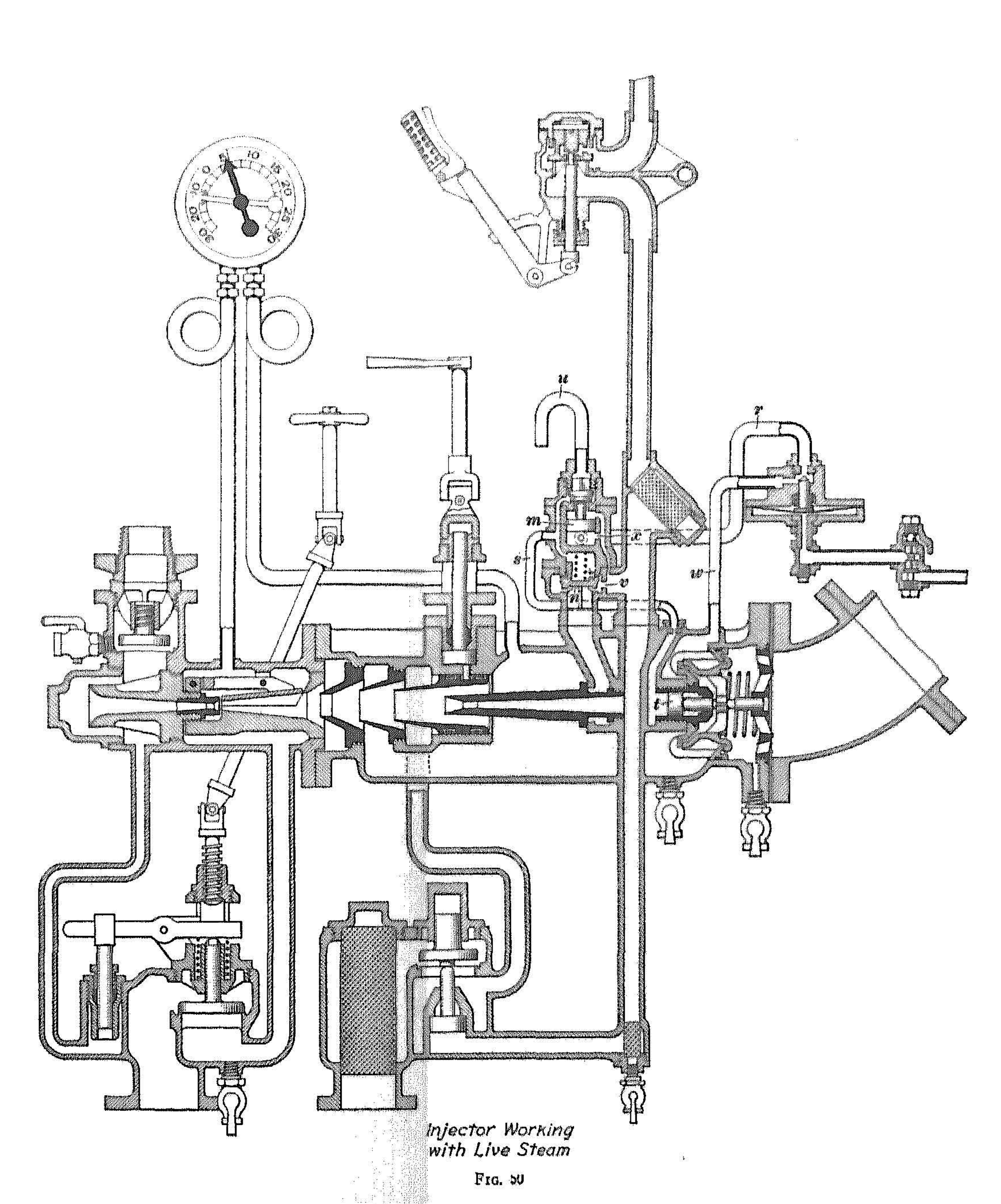
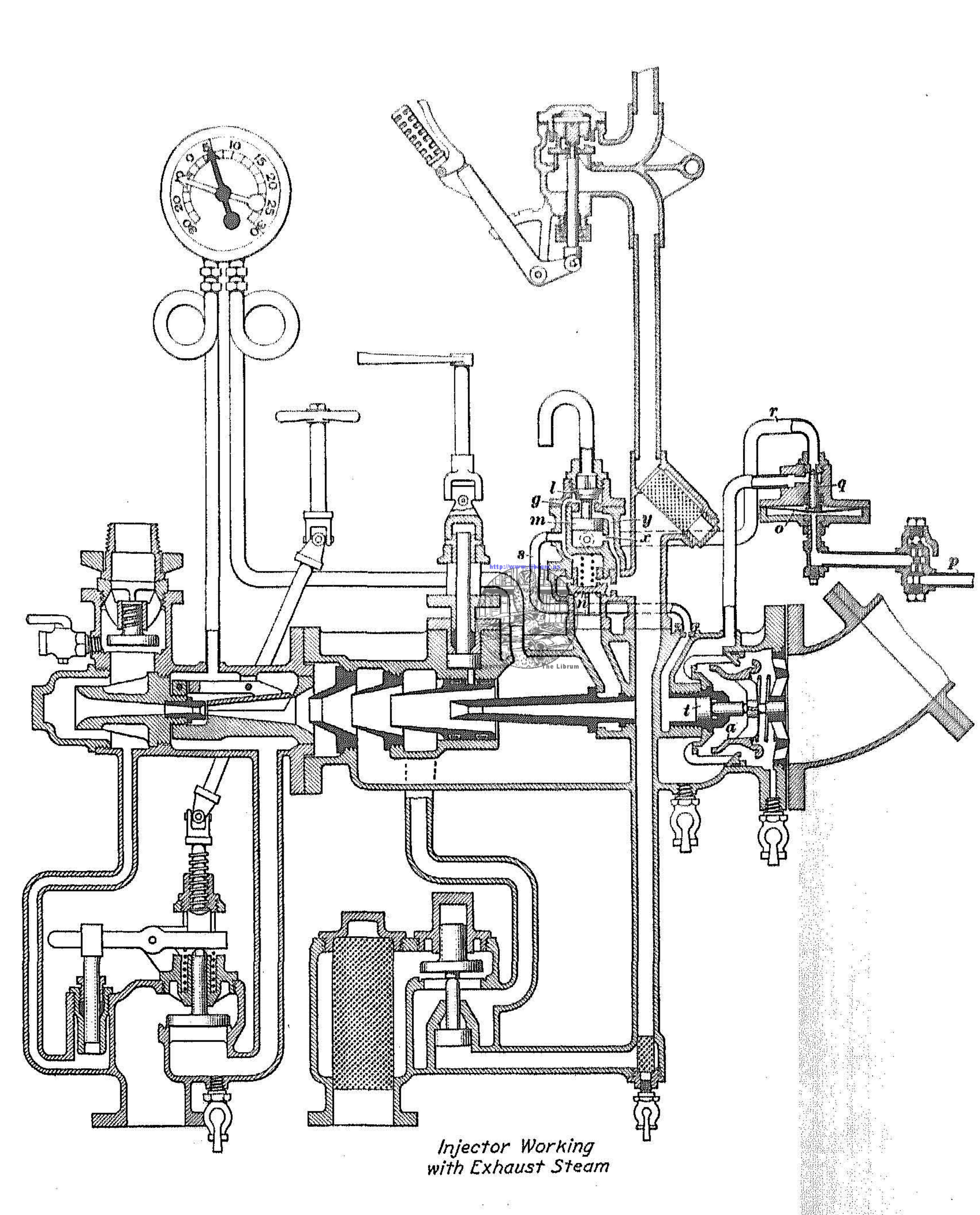

FIG. 50

chamber in the injector is filled with exhaust steam at a pressure that is dependent on the cut-off at which the locomotive is being operated. This steam flows through the main steam nozzle, the front portion of which gradually widens, although this is not apparent in the illustration. Such a construction causes a gradual expansion of the steam, which in turn results in a lowering of its temperature and pressure, and a great increase in its velocity, the velocity of the discharge being about 2,600 feet per second. At the outlet of the nozzle, the steam mingles with the feedwater in the draft nozzle and condenses, this latter action also continuing in the vacuum nozzle, and not only imparts velocity to the water in these nozzles but heats it as well.

The heating and the imparting of velocity to the water are also assisted by the jet of steam that is discharging from the supplementary steam nozzle at a velocity of about 3,050 feet per second.

78. When steam is condensed a vacuum is created, so that the condensation of the steam which begins in the draft nozzle and continues in the vacuum nozzle results in the formation of a partial vacuum in these nozzles. The exhaust steam surrounding these nozzles is much higher in pressure, so it pours into the vacuum nozzle through the annular space between it and the draft nozzle at a velocity of about 2,400 feet per second. The introduction of exhaust steam to the water a second time not only heats the water further but also increases its velocity. In order for this latter jet of exhaust steam to combine as much as possible with the already heated water, a combining tube is placed ahead of the vacuum nozzle. This tube tapers toward the outlet because the amount of steam that is to be condensed lessens as the water moves forwards. The jet of water discharges from the combining nozzle into the delivery nozzle at a velocity of about 100 feet per second. Here the velocity of the jet, owing to the gradual enlargement of the bore of the delivery nozzle, is progressively reduced so that on impact with the slow-moving water in the discharge pipe violent swirls and eddies will not occur and impair the efficiency of the injector. Finally, the pressure of the water in the delivery pipe, owing to the incessant hammering action of the high velocity jet on the column

of water at the rear, will increase to such an extent that the boiler check will be forced open. The temperature of the delivered water will vary from 160° to 235° F.

The end of the main steam nozzle is placed nearer to the feed-water than the tip of the supplementary nozzle, so that the exhaust steam will have the first opportunity to heat and impart velocity to the water. The action of the supplementary jet may be taken as being mainly concerned with imparting velocity to the already heated water, that later will be changed into pressure. Hence, the live-steam jet may be considered as forcing the water, and the exhaust steam as heating the water.

79. The injector, Fig. 48, is started by opening the starting valve; steam then passes through the pipe shown to the supplementary nozzle and to the water valve, keeping it unseated. Also, live steam passes through pipe *s* to the exhaust-valve piston *t* and thus keeps the exhaust valve open. When the injector is being started, the water, prior to the formation of the jet, discharges through the combining-nozzle flap and thence to the ground by way of the overflow valve. The overflow valve is closed by the pressure in the discharge pipe on the overflow-valve piston as soon as the injector starts. The quantity of water delivered can be regulated by moving the main steam nozzle either farther into or out of the draft nozzle by means of the water regulator, thus decreasing or increasing the water supplied to this nozzle. With boiler pressures between 150 and 200 pounds, the injector will work properly with the water regulator one-half to three-quarters open and the black hand of the gauge will then show from 4 to 6 pounds. With any pressure, if the water regulator can be adjusted to work the injector without any spill at the overflow and with the red hand of the gauge approximately at zero, the injector may be assumed to be working satisfactorily.

80. **Live-Steam Operation.**—When operating with live steam the body of the injector fills with live steam at a pressure of about 6 pounds per square inch, this reduction in pressure being accomplished by passing the steam through a small choke *v*

exterior to the automatic valve *n*, Fig. 50. The operation of the injector with the low-pressure live steam and the supplementary jet of steam is the same as already described. During live-steam operation the exhaust valve is held closed by its spring, thereby preventing the escape of the steam to the stack.

81. **Operation of Change-Over Parts.**—The function of the change-over parts is to cause the injector to change automatically from exhaust-steam operation to live-steam operation or the reverse without any action on the part of the engineman. Thus, when the supply of exhaust steam is shut off by closing the throttle, the injector changes over to live-steam operation; when the throttle is opened the injector changes back to exhaust-steam operation again. The change-over parts comprise the relay valve *l*, Fig. 49, the relay piston *m*, an automatic valve *n* and a change-over diaphragm *o*. The purpose of the relay piston and valve is to admit steam to and exhaust steam from the front of the exhaust-valve piston *t*.

Let it be assumed that the engine is drifting with the throttle closed and that the injector is working. The steam that is passing through the starting-valve pipe to the supplementary nozzle also passes up through the passage shown and enters the chamber below the relay piston through the small port *x*, Fig. 50; also, steam passes to the chamber above this piston. The lower face of the piston has more area exposed to the steam than the upper face and the piston would be forced upwards were it not for the fact that the steam beneath the piston is passing out through a small circular port, here shown surrounded by dash lines to pipe *r*, thence by the unseated pin valve to pipe *w* and to the injector body. The relay piston then remains down. There is now no pressure in pipe *s* and on top of the automatic valve *n*, which is accordingly lifted by the steam that enters through the small auxiliary choke *v*. Steam then passes through this choke to the injector at a pressure of about 6 pounds. At this time the exhaust valve is held closed by its spring, as there is no pressure in pipe *s*, so the escape of steam from the injector to the stack is prevented. The injector then operates with low-pressure live steam. The supplementary live-steam jet could at this time be

dispensed with but it is more convenient to use it than to arrange for its elimination.

82. Let it be assumed next that the throttle is opened. As soon as this is done, the exhaust steam that enters pipe p , Fig. 49, from the cylinders forces the change-over diaphragm upwards and seats the pin valve q . The steam under the relay piston that heretofore was escaping through the pipes r and w to the injector is now trapped in pipe r . Hence the relay piston is forced upwards against the pressure above it, and the relay valve l is unseated and at the same time closes the end of pipe u . The steam from the starting-valve pipe then flows through passage y , by the unseated relay valve l to passage g and to pipe s and acts against the exhaust valve piston t , thus opening the exhaust valve. Also, the steam flows from passage g to the top of the automatic valve n and holds it to its seat.

With the exhaust valve held open, the injector operates with exhaust steam supplemented by the live steam that is passing through the supplementary nozzle.

If the throttle is now closed, the relay piston will immediately move down owing to the reduction beneath it in the steam pressure. The steam that was holding the exhaust valve open now escapes through pipe u ; in fact, the sound of the exhaust from this pipe is taken as an outward indication of the change-over.

The change-over from live-steam to exhaust steam and the reverse is then brought about by unbalancing the relay piston.

DUPLEX CAB GAUGE

83. The purpose of the duplex cab gauge is to assist the engineman in the operation of the injector. It not only removes the necessity of his watching the overflow but indicates to him the proper setting of the water regulator for the most efficient and economical boiler feeding.

The gauge face shows a vacuum field below the zero mark and a pressure field above, also a red section in the pressure field. When the gauge hands are properly adjusted, both the red and the black hands will stand at zero with the injector not working. The red hand indicates conditions existing in the combining

nozzle chamber and, for most efficient and economical boiler feeding, the hand should indicate in the vacuum field, or below zero. When the red hand enters the red section, it indicates that the overflow valve is about to open with a consequent loss of water and removes the necessity for the engineman to watch the overflow. The black hand indicates the pressure that is operating the injector either with exhaust or with live steam and when working with live steam indicates to the engineman the approximate setting of the water regulator.

84. When the starting valve is first opened, and while the injector is priming, the black hand will drop back in the vacuum field and at the same time the red hand will go up in the pressure field. Immediately as the injector goes to work, the black hand will move up in the pressure field and the red hand will drop back quickly in the direction of the vacuum field. If the red hand stops at zero or below, no adjustment of the water regulator is required. If it stops in the vicinity of the red section, the position of the black hand will indicate whether the water should be increased or decreased.

When the engine is working, the injector then operating with exhaust steam, a uniform water level will be maintained if the water regulator is adjusted to keep the red hand at zero or below. Any pronounced change in the working of the engine will increase or decrease the steam and water consumption and will be reflected in the exhaust pressure as shown by the black hand, and a like change will be required in the water regulator in order to keep the red hand below the red section and the injector working properly.

85. By watching the position of the black hand on the cab gauge, it can be determined whether or not the injector is working with exhaust steam. If the gauge hand fluctuates as the cut-off and speed are increased or decreased, it indicates exhaust-steam pressure and that the injector is working with exhaust steam. If the hand remains stationary at approximately 6 pounds pressure, which does not change by increasing or decreasing the cut-off, it indicates live-steam pressure and that the injector is

working with live steam. Also, when the change-over from exhaust-steam to live-steam operation occurs upon closing the throttle, the relay release can be heard distinctly in the engine cab. When the change-over from live steam to exhaust steam occurs, a slight puff of steam will be visible at the relay valve release but cannot be heard in the cab.

The duplex cab gauge is of delicate construction and both the red and the black hands are required to indicate correctly with extremely low pressures. In order to maintain the gauge in operation, it must be protected from violent fluctuation of the hands and from steam entering the tubes. Special chokes located in the pipe lines near the gauge prevent violent fluctuations, and the four coils in the gauge piping provide a long water seal and thus prevent steam from entering the tubes.

SELLERS EXHAUST FEEDWATER HEATING EQUIPMENT

DESCRIPTION AND OPERATION

86. **General Description.**—The Sellers exhaust feedwater heating equipment is a system designed for feeding locomotive boilers very hot water. Exhaust steam from the locomotive cylinders is utilized to heat the feedwater which is delivered to the boiler at a temperature of from 250 to 300° Fahrenheit. The heater is made up of two injectors in one casting, one injector being operated by exhaust steam and the other by live steam. The exhaust-steam or heating injector is operated by exhaust steam at a pressure of about 6 pounds and delivers hot water under a pressure of from 15 to 50 pounds to the live-steam injector; by this method the exhaust steam is used to heat the water and the live steam, only a small quantity being required, is used to force the water into the boiler. However, since forcing the water requires condensation of steam, the water must also be heated by the forcing jet. In the absence of exhaust steam the heating injector is operated by live steam at the same pressure as the exhaust steam.

87. The general arrangement of the Sellers exhaust feedwater heating equipment with the parts sectioned is shown in Fig. 51 and comprises an exhaust feedwater heater with its con-

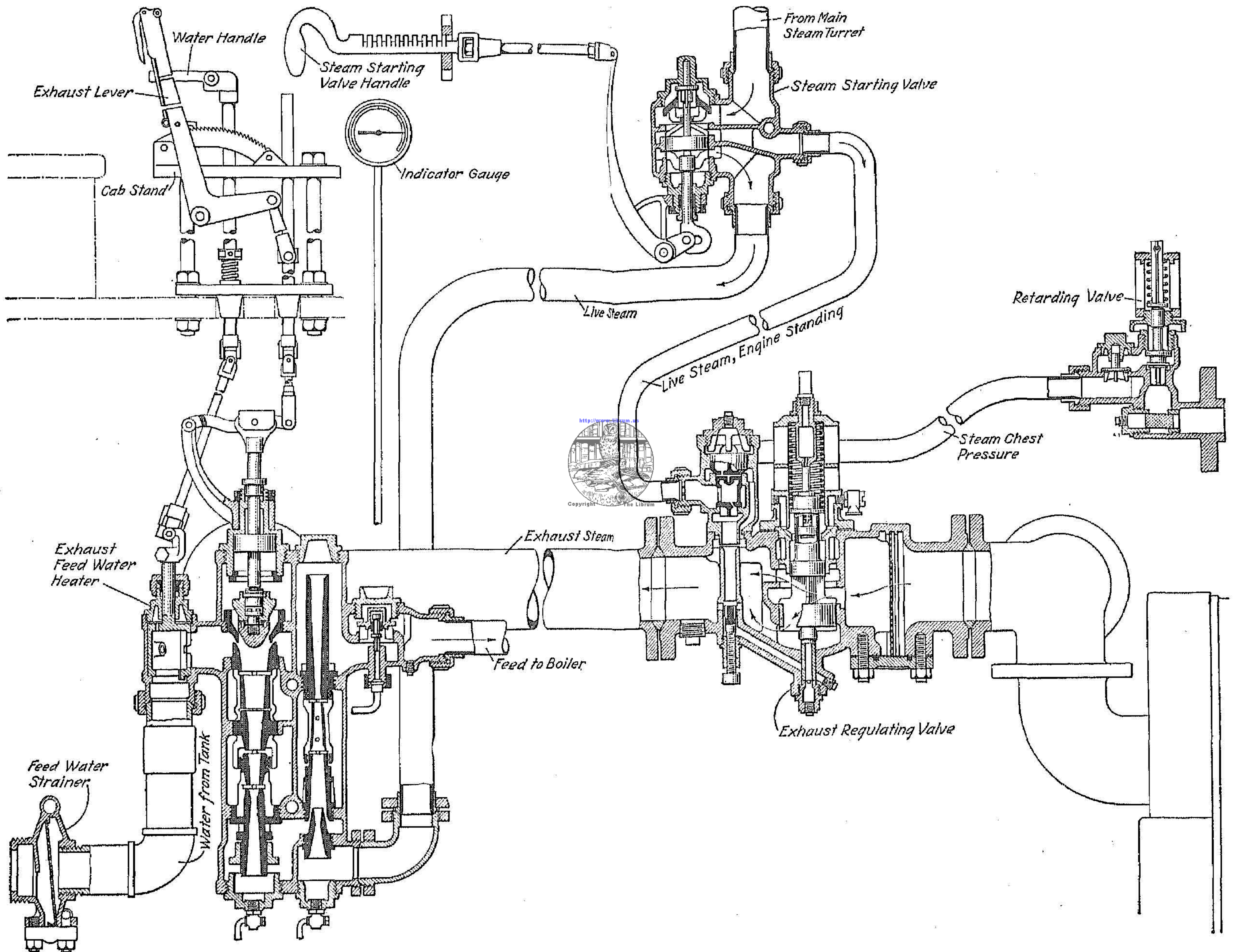

trol apparatus, an exhaust regulating valve, a retarding valve, and the necessary piping to make the connection between the parts.

The exhaust-steam supply for the heater should be taken from the base of the locomotive exhaust-nozzle casting, which should be provided with a fixed deflector to deflect a part of the flow into the supply pipe to the heater. A connection at this point has the feature of receiving all four exhausts from the locomotive cylinders, and this is particularly advantageous on a short cut-off and a light throttle. Where this arrangement is impossible, a cast-steel Y connecting the rear exhaust chambers of both cylinders may be used.

88. Operation.—When the engine is under load, the heater is started by opening wide the cab-stand water handle, next pulling open the cab-stand exhaust lever until the indicator gauge reads about 20 inches of vacuum, and finally pulling open wide the steam starting valve handle.

The exhaust lever opens the exhaust-steam valve in the exhaust-steam nozzle; the exhaust steam that enters from the large supply pipe then condenses with the water, with the result that a jet of water is delivered to the live-steam forcing tubes, shown at the right. Live steam from the steam starting valve enters the heater at the point shown and, discharging through the live-steam nozzle, causes the water to be forced into the boiler. The steam starting valve is also piped to the exhaust regulating valve, but the steam in this pipe is not used until the steam-chest pressure falls below 120 pounds. When this happens, the equipment changes over from exhaust-steam to live-steam operation. The steam in the pipe connecting the starting valve to the exhaust regulating valve then passes into the large supply pipe and replaces the exhaust steam in the exhaust-steam heating tubes of the heater.

When the engine is standing or drifting, the procedure in starting the heater is somewhat different from that just given. After opening the water valve, the steam starting valve is first pulled open one-third way; next, the cab-stand exhaust lever is pulled open until the indicator gauge records about 20 inches

of vacuum; finally the steam starting valve handle is pulled open wide.

89. **Exhaust Feedwater Heater.**—A perspective view of the type BF exhaust feedwater heater is shown in Fig. 52 and a sectional view in Fig. 53. The operation of the device does not differ from that of the ordinary injector, so that a detailed

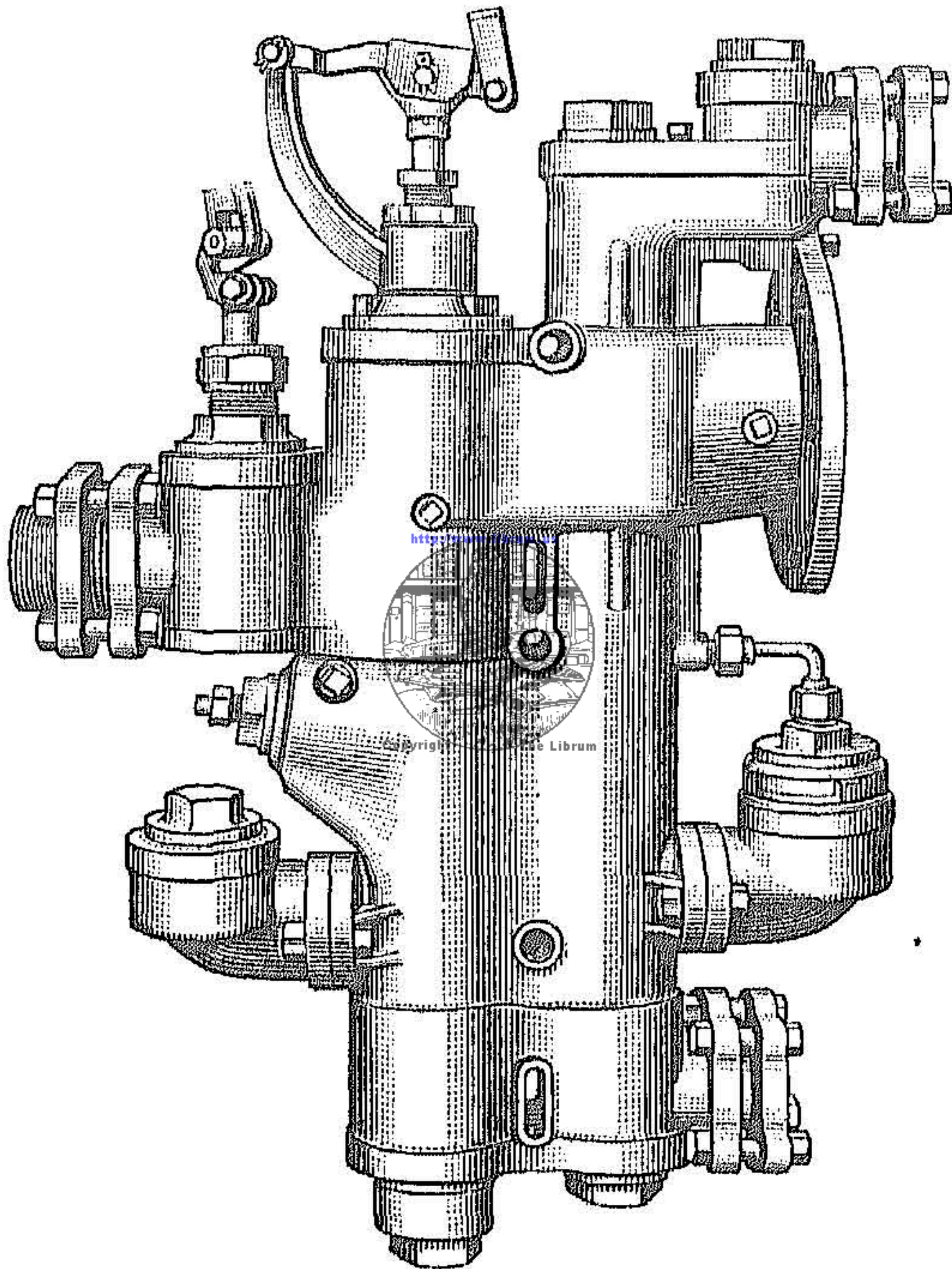

FIG. 52

description is unnecessary. Pulling back the cab-stand exhaust lever draws the exhaust-steam valve *a* away from its seat on the steam nozzle, thereby permitting the exhaust steam to mingle with the water in the combining tube, the water entering by way of the water valve *b*. Until the steam condenses and the jet of water forms, the surplus water discharges through the slots in the combining tube *c* to the upper overflow valve *d* and thence through the lower overflow valve *e* to the ground. After

the formation of the jet, the overflow valves close, as the pressure in the combining tube is now less than that of the atmosphere, the water then flows through the delivery tube *f* from whence

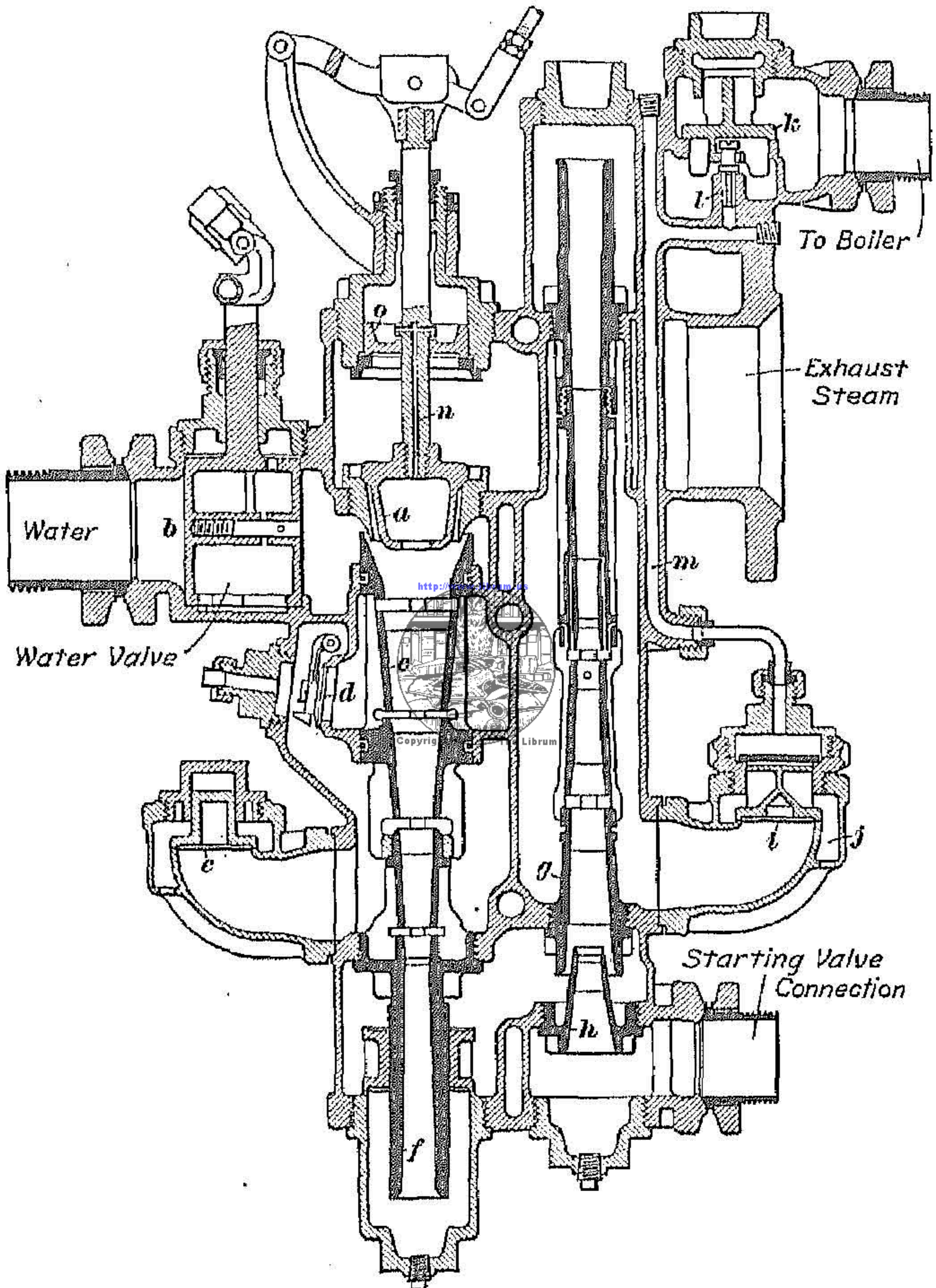

FIG. 53

it passes under pressure to the forcing combining tube *g*. Here the water meets the steam that is passing from the starting valve through the forcing steam nozzle *h*, a jet of water forms, which, in passing through the forcing delivery tube, acquires sufficient

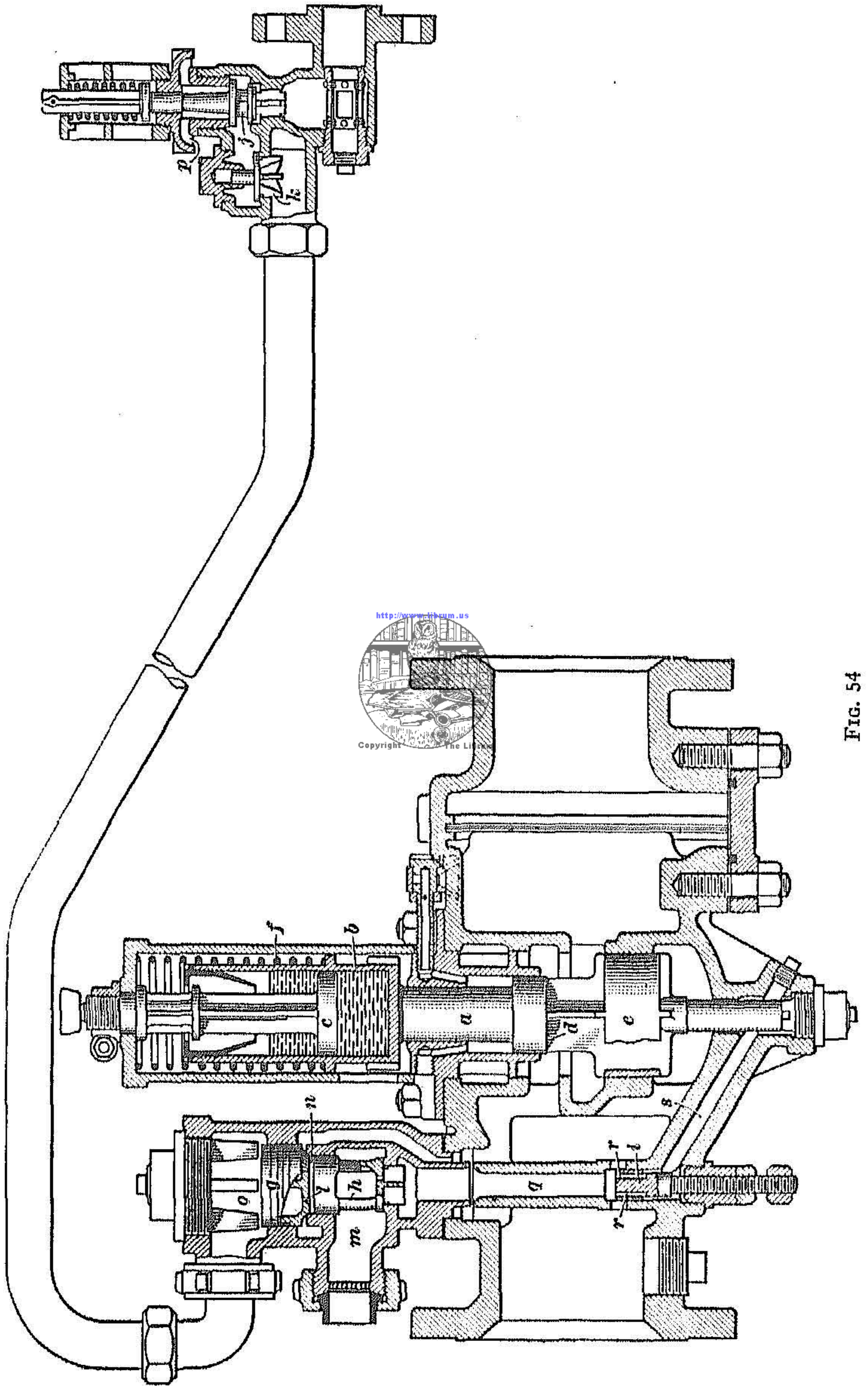

FIG. 54

pressure to open the boiler check. Before the jet forms, the water passes out through the openings shown in the forcing combining tube and, unseating the final overflow valve *i*, escapes through the openings *j* to the ground. But when the line check *k* opens, the water passes down by the pilot valve *l* and through the passage *m* to the top of the valve *i* and seats it. The valve has a rubber disk that prevents the water that is holding it closed from entering the body of the injector. The final overflow valve must be held forcibly closed, as the chamber beneath is full of water under a pressure of 50 pounds. The passage *n* in the stem of the exhaust-steam valve prevents the valve from flying open after being cracked, as the steam passes on top of the piston *o* and imposes a load on the valve.

AUTOMATIC CHANGE-OVER OPERATION

90. **General Explanation.**—The equipment is caused to change automatically from exhaust-steam operation to live-steam operation or the reverse by the combined action of the retarding valve and the exhaust regulating valve. The retarding valve, which is attached to the steam-chest pipe, opens when the steam chest pressure is 120 pounds or over, and causes the exhaust regulating valve to supply the exhaust steam heating tubes of the heater with exhaust steam at a pressure of about 6 pounds. When the throttle is closed, the action of the retarding valve is such as to cause the exhaust regulating valve to supply the heating tubes of the heater with live steam at the same pressure as the exhaust steam previously used.

91. **Operation With Exhaust Steam.**—The exhaust regulating valve admits and regulates the pressure of the exhaust steam to the heater to 6 pounds when the engine is operating, and automatically substitutes live steam of the same pressure for exhaust steam when the engine is standing or at any time when the steam-chest pressure falls below 120 pounds. The portion of the valve at the right, which includes a piston regulating valve *a*, Fig. 54, connected to and operating a hollow damper cylinder *b* filled with oil, and a stationary piston *c*, are the parts of the valve that operate when the heater is working with

exhaust steam. When the steam delivered from the cylinders to the supply pipe exceeds a pressure of 6 pounds, this pressure acting on the area d of the piston regulating valve will move it upwards to closed position, in which position the part e of the valve cuts off the passage of steam; when the pressure decreases, the compression of the spring f on the cylinder will open the valve. Owing to the constant fluctuation in the pressure of the exhaust steam the valve is continually moving up and down, and the oil-filled cylinder is designed to prevent this action from occurring too quickly. When the cylinder moves up, some of the oil is forced by the piston, owing to its loose fit, to the upper end of the cylinder, and on the downward movement a portion of the oil is transferred to the bottom end of the cylinder, hence the movement of the parts is retarded.

92. **Operation With Live Steam.**—The portion of the valve shown at the left, which comprises the closing piston g , Fig. 54, the live-steam valve h , and the live-steam choke i , are the parts of the exhaust regulating valve that cause the heater to operate wholly with live steam. During exhaust-steam operation the main valve j of the retarding valve is unseated as the steam-chest pressure exceeds the tension of its spring, or 120 pounds. The steam then passes through a drilled hole in the check-valve k and passes through a pipe that leads to the top of the closing piston in the exhaust regulating valve.

The steam leaks down through the small port l in the closing piston and holds the live-steam valve seated against the pressure in chamber m and in the starting-valve pipe. When the pressure in the steam chest falls below 120 pounds, the main valve in the retarding valve seats and the steam in chambers n and o as well as in the pipe to the retarding valve vents to the atmosphere at p . The steam in chamber m , acting on the somewhat greater upper area of the live-steam valve, then unseats it and the closing piston as well. Steam now passes through the passage q and through the restricted ports r in the live-steam choke i , which reduces the pressure to about 6 pounds, depending on its adjustment and thence to the steam heating tubes in the heater. Some of the steam continues down through passage s to the stem of the

piston regulating valve and forces it up, thereby closing the valve, and preventing the steam from passing back through the supply pipe to the exhaust passages in the stack.

93. Condensation of Steam With Hot Water.—Steam condenses back to water again at the same temperature that it boils and forms steam. Thus, if water boils at a temperature of 212° F., the steam condenses and returns to water as soon as the temperature is lowered even the slightest degree. Now the temperature at which water boils increases as the pressure on the water becomes greater; for example, in an open vessel and hence under atmospheric pressure, water boils at 212° F., whereas under a pressure of 50 pounds, the temperature must be increased to about 297° F. before the steam particles will be thrown off. As already pointed out, the condensing temperature of steam is the same as the boiling point, so that condensation occurs at higher temperatures as the pressure of the water is increased.

94. From the foregoing it follows that, if a jet of steam is directed into a body of water, the steam will begin to condense when its temperature lowers to about the point at which the water itself would turn into steam. It is assumed, of course, that the temperature of the water is so low that the incoming steam does not raise the water above the boiling point; if it did, the steam would not then condense. Thus, with high-temperature steam discharging into water in an open vessel, condensation will start when the temperature of the steam reduces to 212° F., provided the temperature of the water is already such that the steam does not heat it to this temperature. Similarly, with water under a pressure of 50 pounds and at a sufficiently low temperature, the steam will start to condense at the temperature that corresponds to the boiling point of water at this pressure, or at about 297° F. Therefore, in order to have high-temperature steam condense with hot water it is merely necessary to have the water at a temperature somewhat less than that corresponding to its pressure.

95. The foregoing condition is met with in injectors where water from one nozzle or set of nozzles is delivered to another

nozzle at a temperature less than the corresponding pressure. The foregoing explains why the live steam with the Sellers exhaust feedwater heater condenses with and forces into the boiler the already heated water that is delivered to the forcing tubes at a pressure of about 50 pounds and at a temperature of about 185° F.

96. The application of the principle that steam will condense readily with hot water provided that the water is first placed under pressure without heating it too much, is not confined to exhaust-steam injectors alone; because all live-steam injectors are so arranged that the water is lifted, heated, and delivered under pressure by one nozzle to another, or to a forcing nozzle. This feature is particularly evident with the Hancock inspirator, with its lifting and forcing nozzles, as well as with the Sellers injector, with its somewhat different arrangement of *lifting and forcing nozzles*. Such an arrangement of nozzles causes the water to be delivered to the boiler at a higher temperature than otherwise, because with the water delivered to a forcing set of tubes under atmospheric pressure the temperature of the delivered water would always be less than 212° F. The ordinary injector, however, owing to its two-stage pressure arrangement, delivers water at minimum capacity at about 260° F.



A Librum
(<http://www.librum.us>)
RESTORATION.

*This file is in the public domain,
used with the permission of
the copyright holder of record,
or is under registered copyright
held by the Librum and/or the
ICS Archive.*

*This free pdf is hosted by the Librum,
and/or the ICS Archive, and hosted
on the noted websites.*

*<http://www.librum.us>
<http://www.icsarchive.org>*

Thank you for your support.